

Features

- ✧ UL Recognized File # E-326854
- ✧ Low forward voltage drop, Low power loss
- ✧ High efficiency
- ✧ Meet MSL level 1, per J-STD-020D, Lead free maximum peak of 245°C
- ✧ Solder dip 265°C max, 10s, per JESD 22-A111
- ✧ Compliant to RoHS directive 2002/95/EC and in accordance to WEEE 2002/96/EC
- ✧ Green compound with suffix "G" on packing code & prefix "G" on datecode



Mechanical Data

- ✧ Case: D²PAK
- ✧ Molding Compound meet UL 94V-0 flammability rating
- ✧ Terminals: Pure tin plated, lead free, solderable per J-STD-002B, and JESD22-B102D
- ✧ Polarity: As marked
- ✧ Weight: 1.35 grams

Ordering Information

Part No.	Package	Packing	Packing code	Green Compound Packing code
MBRS15H45CT	D2PAK	800 / 13" REEL	RN	RNG

Maximum Ratings and Electrical Characteristics

Rating at 25 °C ambient temperature unless otherwise specified.

Single phase, half wave, 60 Hz, resistive or inductive load.

For capacitive load, derate current by 20%

Type Number	Symbol	MBRS 15H45CT		Unit
Maximum Repetitive Peak Reverse Voltage	V_{RRM}	45		V
Maximum RMS Voltage	V_{RMS}	31		V
Maximum DC Blocking Voltage	V_{DC}	45		V
Maximum Average Forward Rectified Current	$I_{F(AV)}$	15		A
Peak Repetitive Surge Current (Rated V_R , Square Wave, 20KHz)	$I_{F(RMS)}$	15		A
Peak Forward Surge Current, 8.3 ms Single Half Sine-wave Superimposed on Rated Load	I_{FSM}	150		A
Peak Repetitive Reverse Surge Current (Note 1)	I_{RRM}	1		A
Maximum Instantaneous Forward Voltage (Note 2) IF=7.5A, $T_A=25^\circ C$ IF=7.5A, $T_A=125^\circ C$ IF=15A, $T_A=25^\circ C$ IF=15A, $T_A=125^\circ C$	V_F	TYP	MAX	V
		0.64	0.68	
		0.55	0.6	
		0.76	0.8	
Maximum Reverse Current @ Rated V_R $T_A=25^\circ C$ $T_A=125^\circ C$	I_R	TYP	MAX	uA mA
		0.3	30	
		0.62	10	
Voltage Rate of Change,(Rated V_R)	dV/dt	10000		V/us
Typical Junction Capacitance (Note 3)	C_j	290		pF
Typical Thermal Resistance	$R_{\theta JC}$	2		$^\circ C/W$
Operating Temperature Range	T_J	- 65 to + 175		$^\circ C$
Storage Temperature Range	T_{STG}	- 65 to + 175		$^\circ C$

Note 1: 2.0uS Pulse Width, F=1.0KHz, Continues 10 Cycles

Note 2: Pulse Test : 300uS Pulse Width, 1% Duty Cycle

Note 3: Measure at 1 MHz and Applied Reverse Voltage of 4.0 V D.C.

RATINGS AND CHARACTERISTIC CURVES (MBRS15H45CT)

FIG. 1 FORWARD CURRENT DERATING CURVE

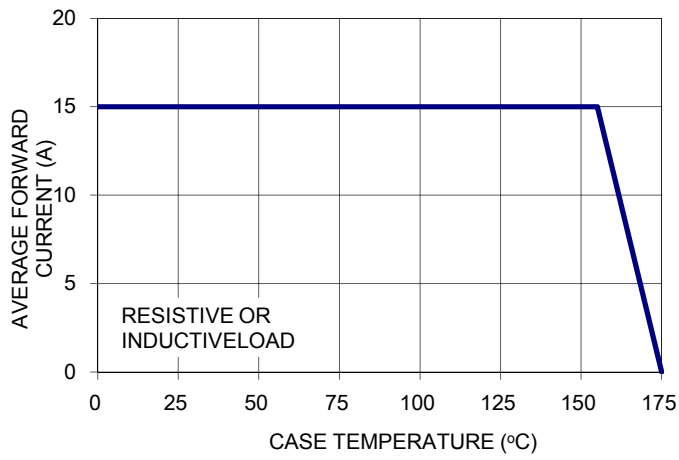

FIG. 2 MAXIMUM NON-REPETITIVE FORWARD SURGE CURRENT PER LEG

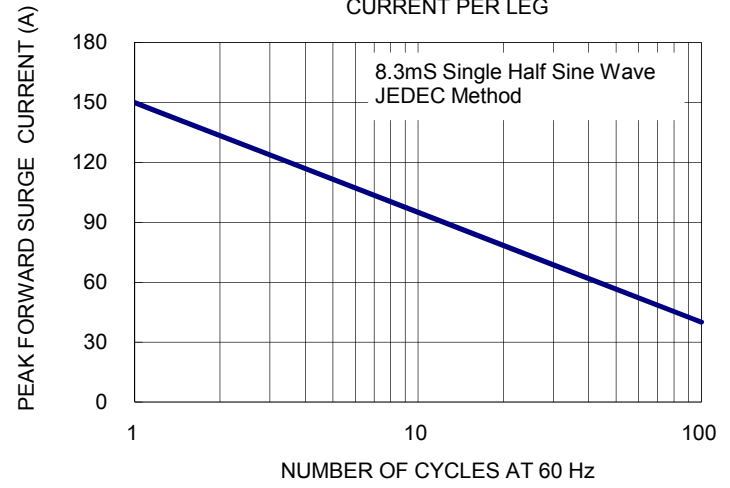

FIG. 3 TYPICAL FORWARD CHARACTERISTICS

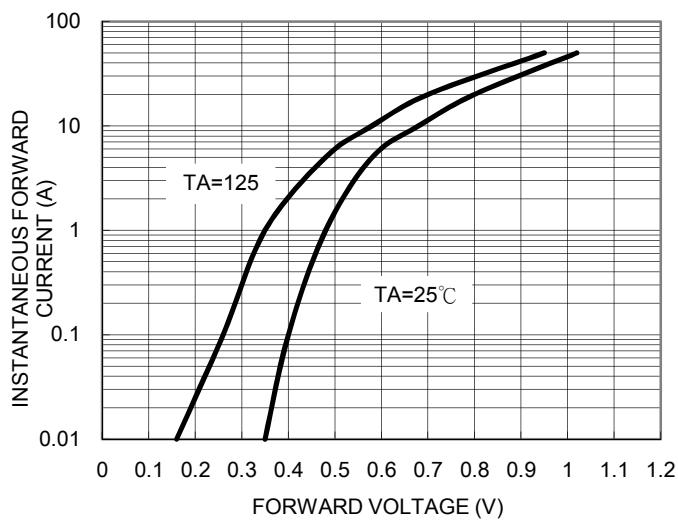

FIG. 4 TYPICAL REVERSE CHARACTERISTICS

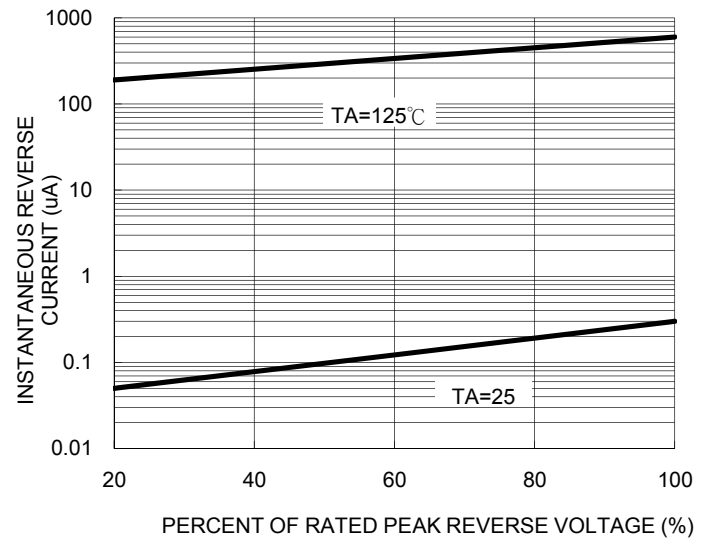

FIG. 5 TYPICAL JUNCTION CAPACITANCE

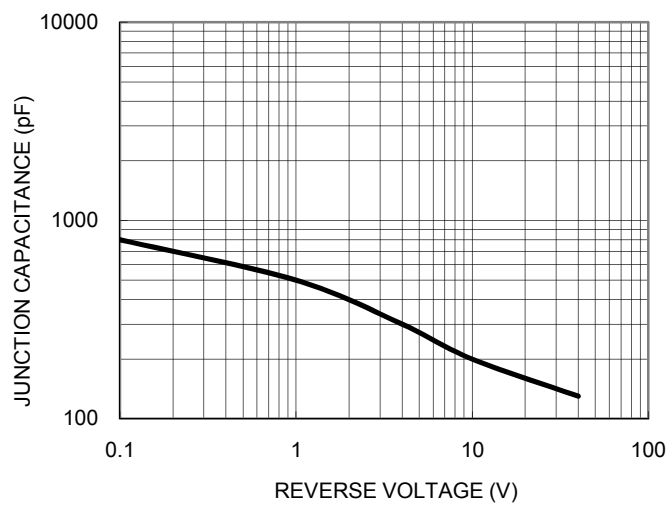
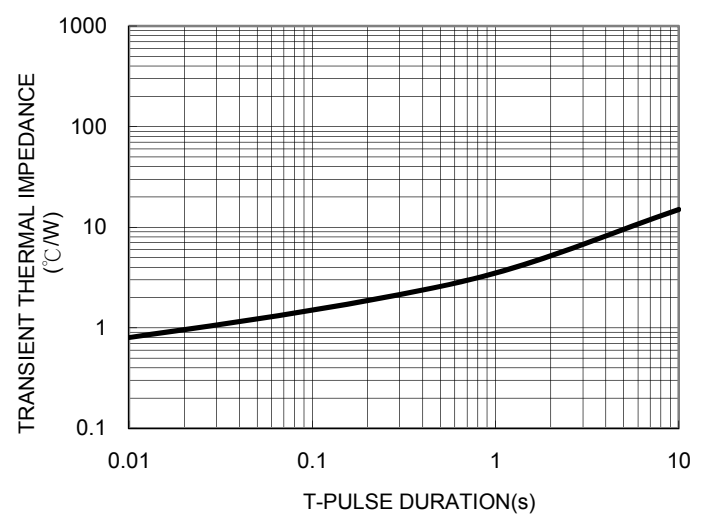
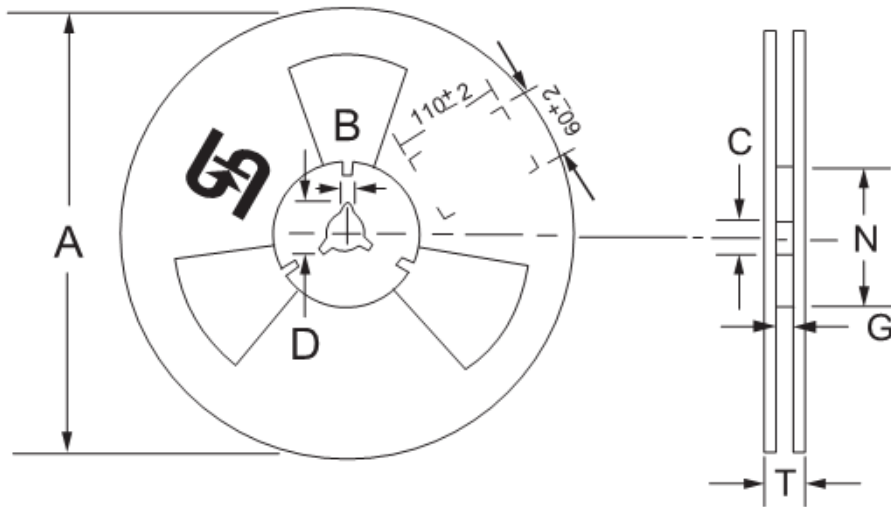
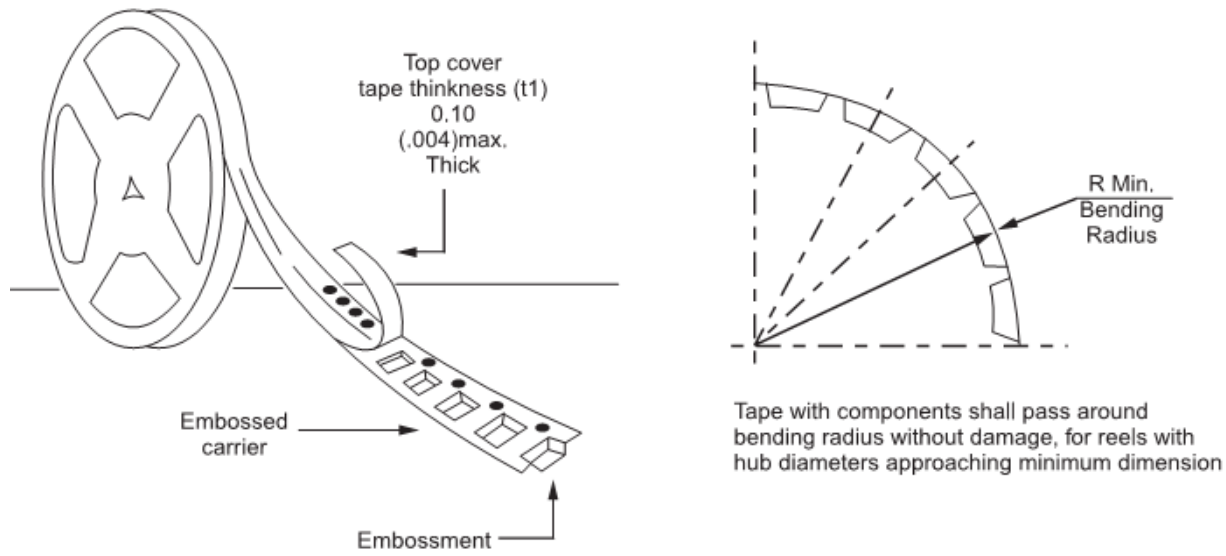

FIG. 6 TYPICAL TRANSIENT THERMAL IMPEDANCE



Tape & Reel specification



Reel Size	Tape Size	A	B	C	D	N	G	T
		max	± 0.5	± 0.5	min	± 0.5	+2.0;-0	max
13"	24mm	330	2	13	20.2	75	24.4	30.4

Unit (mm)

Suggested PAD Layout

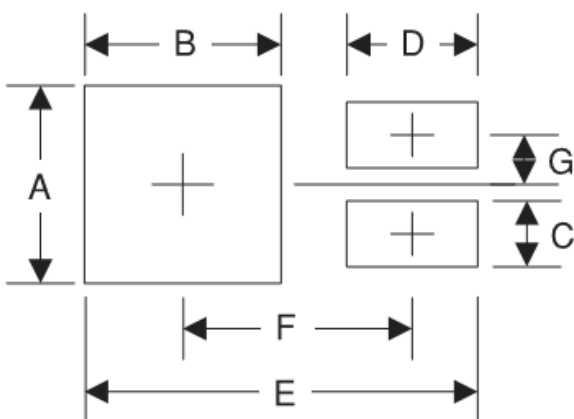

Symbol	Unit(mm)
A	10.8
B	7
C	1.1
D	3.5
E	16.9
F	9.5
G	2.5

Dimensions

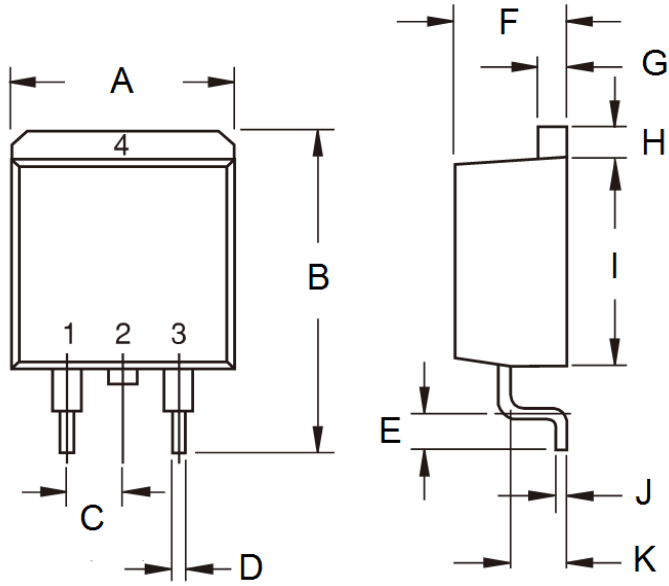

DIM.	Unit(mm)		Unit(inch)	
	Min	Max	Min	Max
A	-	10.5	-	0.413
B	14.60	15.88	0.575	0.625
C	2.41	2.67	0.095	0.105
D	0.68	0.94	0.027	0.037
E	2.29	2.79	0.090	0.110
F	4.44	4.70	0.175	0.185
G	1.14	1.40	0.045	0.055
H	1.14	1.40	0.045	0.055
I	8.25	9.25	0.325	0.364
J	0.36	0.53	0.014	0.021
K	2.03	2.79	0.080	0.110

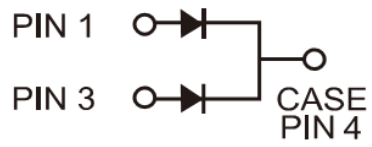

Marking Diagram



P/N = Specific Device Code
 G = Green Compound
 YWW = Date Code