

Features

- ✧ UL Recognized File #E-326854
- ✧ For surface mounted application
- ✧ Plastic material used carriers Underwriters Laboratory Classfication 94V-0
- ✧ Metal to silicon junction, majority carrier conduction
- ✧ Low power loss, high efficiency
- ✧ High current capability, low forward voltage drop
- ✧ High surge current capability
- ✧ For use in low voltage, high frequency inverters, free wheeling, and polarity protection applications
- ✧ Guarding for overvoltage protection
- ✧ High temperature soldering guaranteed: 260°C/10s at terminals
- ✧ Green compound with suffix "G" on packing code & prefix "G" on datecode



Mechanical Data

- ✧ Case: JEDEC D²PAK Molded plastic
- ✧ Terminal: Pure tin plated, lead free, solderable per MIL-STD-750, Method 2026
- ✧ Polarity: As marked
- ✧ Mounting position: Any
- ✧ Mounting torque: 5 in.-lbs. max
- ✧ Weight: 1.37 gram

Ordering Information

Part No.	Package	Packing	Packing code	Green Compound Packing code
MBRS25xxCT	D2PAK	800 / 13" REEL	RN	RNG

Note: "x" is Device Code from "35" thru "150".

Maximum Ratings and Electrical Characteristics

Rating at 25 °C ambient temperature unless otherwise specified.

Single phase, half wave, 60 Hz, resistive or inductive load.

For capacitive load, derate current by 20%

Type Number	Symbol	MBRS	MBRS	MBRS	MBRS	MBRS	MBRS	MBRS	Unit
		2535 CT	2545 CT	2550 CT	2560 CT	2590 CT	25100 CT	25150 CT	
Maximum Repetitive Peak Reverse Voltage	V _{RRM}	35	45	50	60	90	100	150	V
Maximum RMS Voltage	V _{RMS}	24	31	35	42	63	70	105	V
Maximum DC Blocking Voltage	V _{DC}	35	45	50	60	90	100	150	V
Maximum Average Forward Rectified Current	I _{F(AV)}	25							A
Peak Repetitive Forward Current (Rated V _R , Square Wave, 20KHz)	I _{FRM}	25							A
Peak Forward Surge Current, 8.3 ms Single Half Sine-wave Superimposed on Rated Load (JEDEC method)	I _{FSM}	200							A
Peak Reperitive Reverse Surge Current (Note 1)	I _{RSM}	1.0	0.5					A	
Maximum Instantaneous Forward Voltage (Note 2) IF=12.5A @ 25°C IF=12.5A @ 125°C IF=25.0A @ 25°C IF=25.0A @ 125°C	V _F	0.65 0.55 0.82 0.73	0.75 0.65 0.90 0.80	0.85 0.75 0.92 0.88	0.95 0.92 1.02 0.98				V
Maximum Instantaneous Reverse Current T _A =25 °C at Rated DC Blocking Voltage Per Leg T _A =125 °C	I _R	0.2 15	0.2 10	0.1 7.5	0.1 5				mA
Voltage Rate of Change (Rated V _R)	dV/dt	10000							V/uS
Typical Thermal Resistance	R _{θJC}	1.0							°C/W
Operating Temperature Range	T _J	- 65 to + 150							°C
Storage Temperature Range	T _{STG}	- 65 to + 175							°C

Note 1: 2.0us Pulse Width, f=1.0KHz

Note 2: Pulse Test: 300us Pulse Width, 1% Duty Cycle

RATINGS AND CHARACTERISTIC CURVES (MBRS2535CT THRU MBRS25150CT)

FIG. 1 FORWARD CURRENT DERATING CURVE

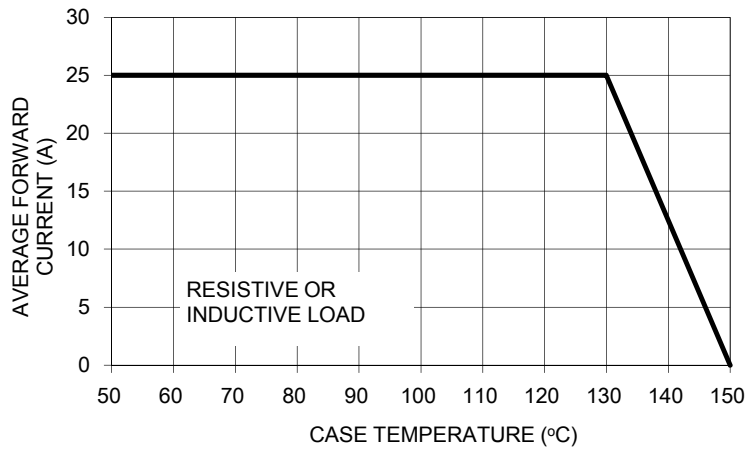

FIG. 2 MAXIMUM NON-REPETITIVE FORWARD SURGE CURRENT PER LEG

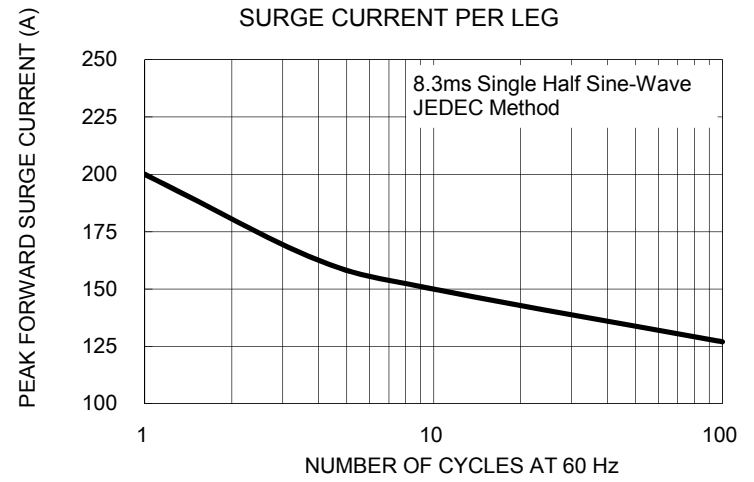

FIG. 3 TYPICAL FORWARD CHARACTERISTICS PER LEG

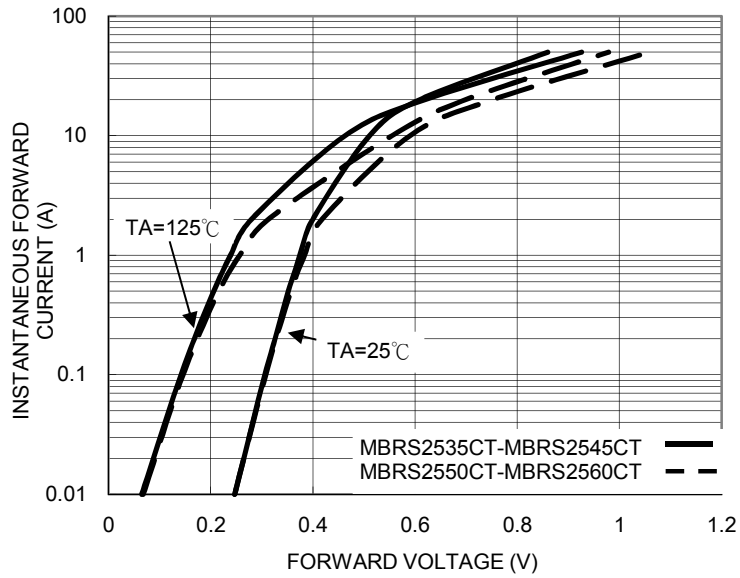

FIG. 4 TYPICAL FORWARD CHARACTERISTICS PER LEG

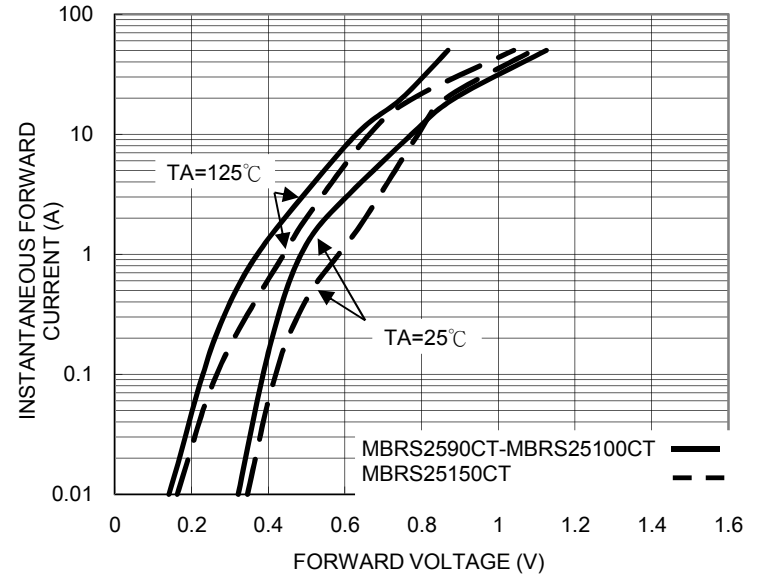

FIG. 5 TYPICAL REVERSE CHARACTERISTICS PER LEG

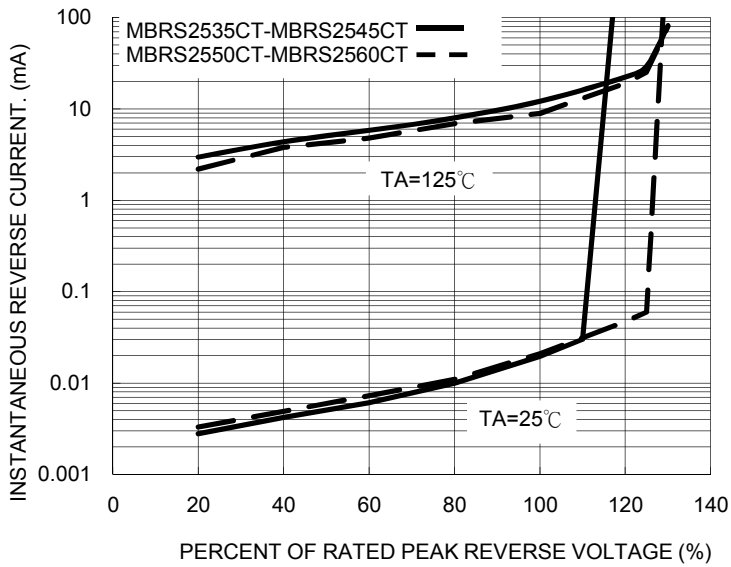
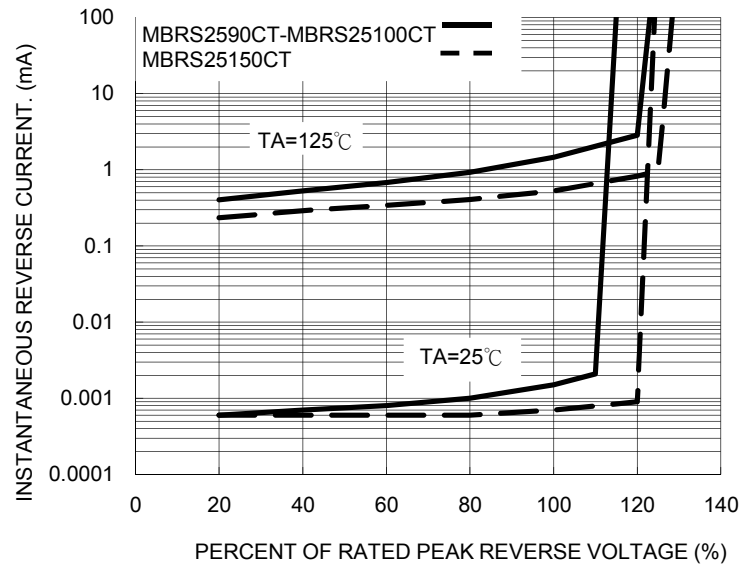

FIG. 6 TYPICAL REVERSE CHARACTERISTICS PER LEG



RATINGS AND CHARACTERISTIC CURVES (MBRS2535CT THRU MBRS25150CT)

FIG. 7 TYPICAL JUNCTION CAPACITANCE PER LEG

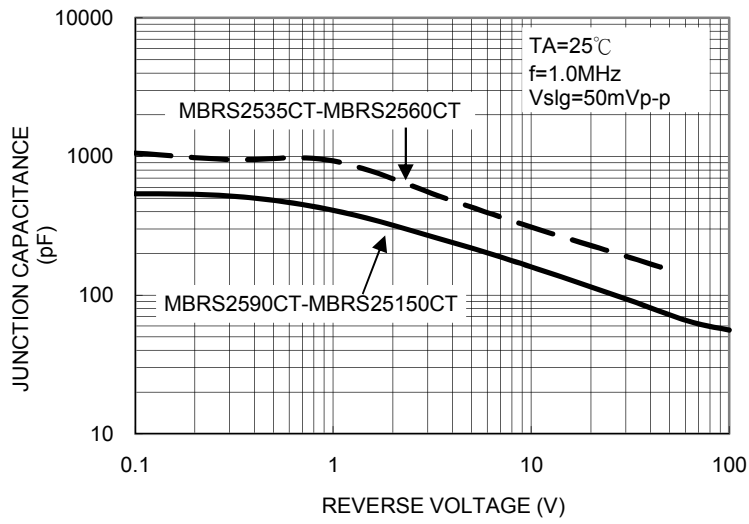
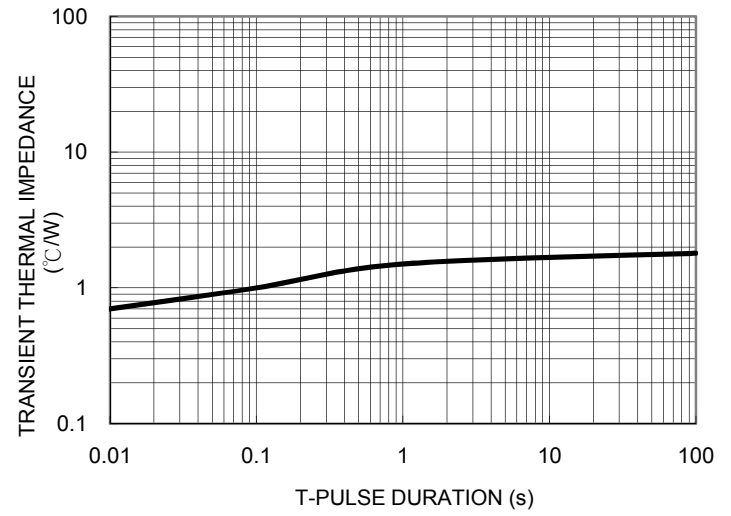
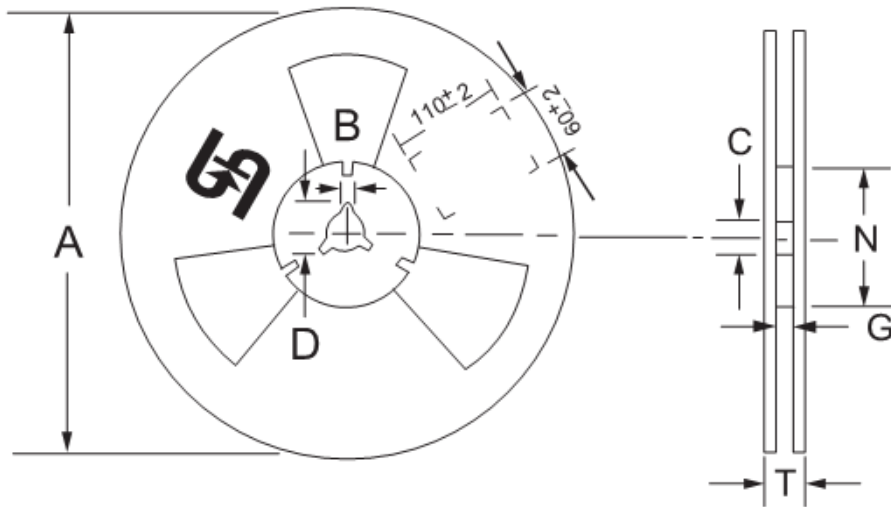
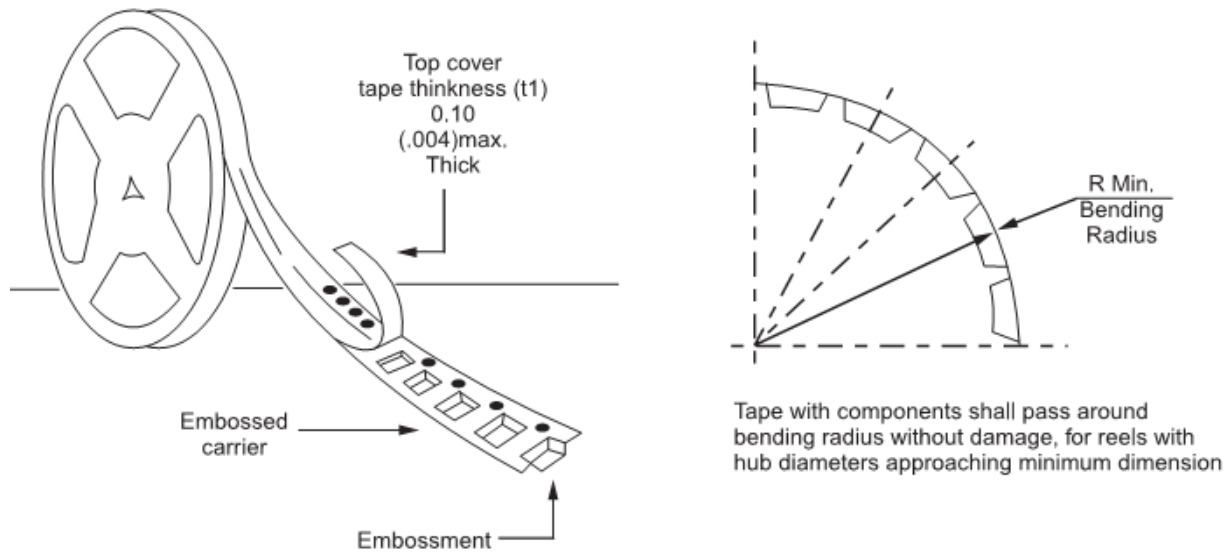

FIG. 8 TYPICAL TRANSIENT THERMAL IMPEDANCE PER LEG



Tape & Reel specification



Reel Size	Tape Size	A	B	C	D	N	G	T
		max	±0.5	±0.5	min	±0.5	+2.0;-0	max
13"	24mm	330	2	13	20.2	75	24.4	30.4

Unit (mm)

Suggested PAD Layout

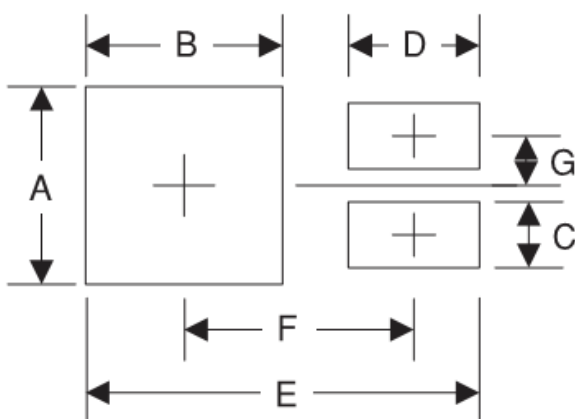

Symbol	Unit(mm)
A	10.8
B	7
C	1.1
D	3.5
E	16.9
F	9.5
G	2.5

Dimensions

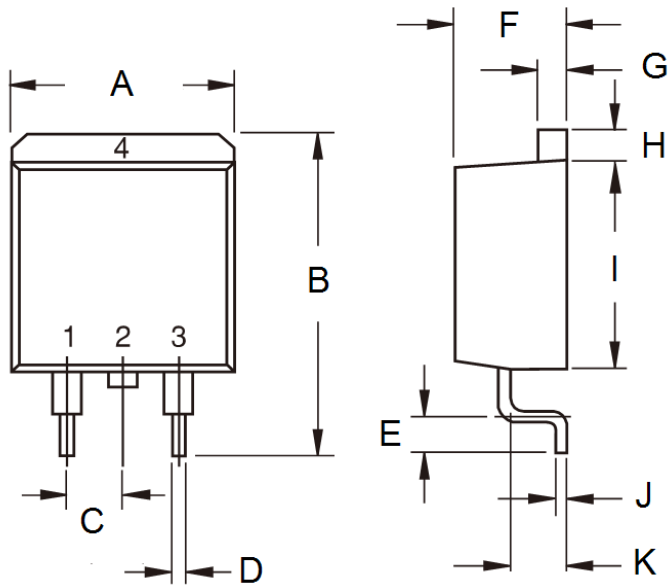

DIM.	Unit(mm)		Unit(inch)	
	Min	Max	Min	Max
A	-	10.5	-	0.413
B	14.60	15.88	0.575	0.625
C	2.41	2.67	0.095	0.105
D	0.68	0.94	0.027	0.037
E	2.29	2.79	0.090	0.110
F	4.44	4.70	0.175	0.185
G	1.14	1.40	0.045	0.055
H	1.14	1.40	0.045	0.055
I	8.25	9.25	0.325	0.364
J	0.36	0.53	0.014	0.021
K	2.03	2.79	0.080	0.110

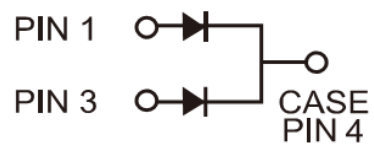

Marking Diagram



- P/N = Specific Device Code
- G = Green Compound
- YWW = Date Code