

Features

- ✧ Low power loss, High efficiency
- ✧ High current capability, low VF
- ✧ High reliability
- ✧ High surge current capability
- ✧ Epitaxial construction
- ✧ Guard-ring for transient protection
- ✧ For use in low voltage, high frequency inverter, free wheeling, and polarity protection application
- ✧ Green compound with suffix "G" on packing code & prefix "G" on datecode

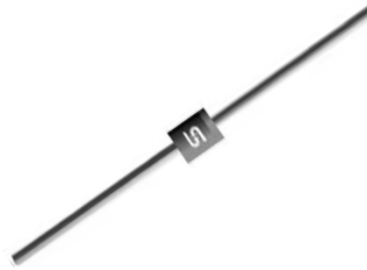

Mechanical Data

- ✧ Cases: DO-201AD Molded plastic
- ✧ Epoxy: UL 94V-0 rate flame retardant
- ✧ Lead: Pure tin plated, lead free, solderable per MIL-STD-202, Method 208 guaranteed
- ✧ High temperature soldering guaranteed: 260°C/10s / .375", (9.5mm) lead lengths at 5 lbs, (2.3kg) tension
- ✧ Weight: 1.1 grams

Ordering Information (example)

Part No.	Package	Packing	INNER TAPE	Packing code	Green Compound Packing code
SR302	DO-201AD	500 / AMMO box	52mm	A0	A0G

Maximum Ratings and Electrical Characteristics

Rating at 25 °C ambient temperature unless otherwise specified.

Single phase, half wave, 60 Hz, resistive or inductive load.

For capacitive load, derate current by 20%

Type Number	Symbol	SR 302	SR 303	SR 304	SR 305	SR 306	SR 309	SR 310	SR 315	SR 320	Units
Maximum Recurrent Peak Reverse Voltage	V_{RRM}	20	30	40	50	60	90	100	150	200	V
Maximum RMS Voltage	V_{RMS}	14	21	28	35	42	63	70	105	140	V
Maximum DC Blocking Voltage	V_{DC}	20	30	40	50	60	90	100	150	200	V
Maximum Average Forward Rectified Current	$I_{F(AV)}$	3									A
Peak Forward Surge Current, 8.3 ms Single Half Sine-wave Superimposed on Rated Load (JEDEC method)	I_{FSM}	80									A
Maximum Instantaneous Forward Voltage (Note 1) @ 3 A	V_F	0.55		0.70		0.85		0.95			V
Maximum DC Reverse Current at Rated DC Blocking Voltage @ $T_A=25^\circ\text{C}$ @ $T_A=100^\circ\text{C}$ @ $T_A=125^\circ\text{C}$	I_R	0.5		0.5		0.1				mA	
		10		5		-					
		-		-		2.0					
Typical Junction Capacitance (Note 2)	C_j	160		130		90				pF	
Typical Thermal Resistance	$R_{\theta JA}$	50									$^\circ\text{C/W}$
	$R_{\theta JC}$	15									
Operating Junction Temperature Range	T_J	- 65 to + 125			- 65 to + 150						$^\circ\text{C}$
Storage Temperature Range	T_{STG}	- 65 to + 150									$^\circ\text{C}$

Note1: Pulse Test with PW=300u sec, 1% Duty cycle

Note2: Measured at 1 MHz and Applied Reverse Voltage of 4.0V D.C.

RATINGS AND CHARACTERISTIC CURVES (SR302 THRU SR320)

FIG. 1 FORWARD CURRENT DERATING CURVE

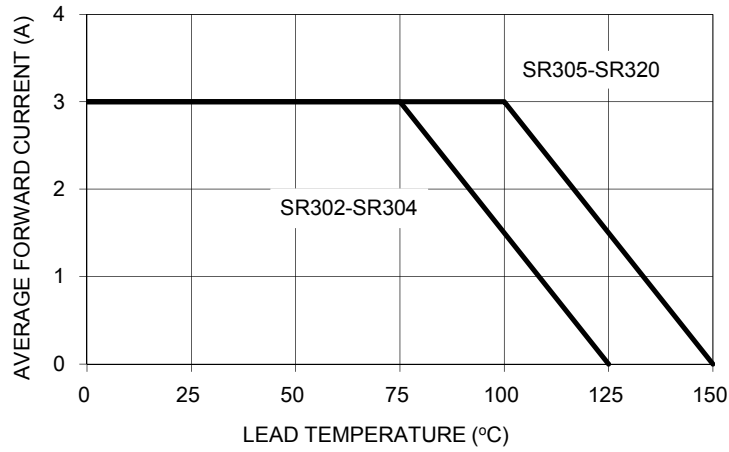

FIG. 2 MAXIMUM FORWARD SURGE CURRENT

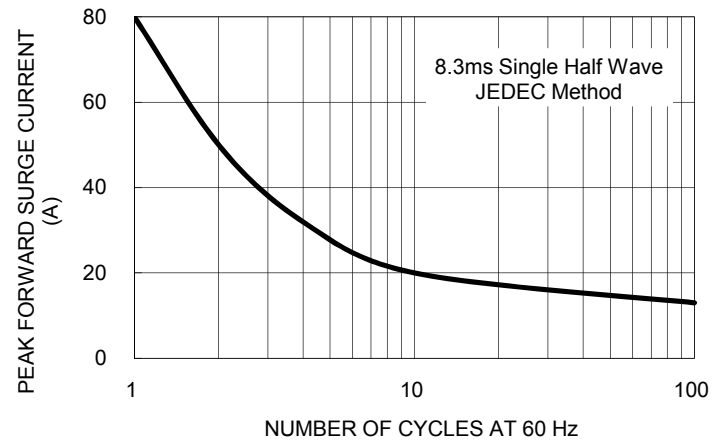

FIG. 3 TYPICAL FORWARD CHARACTERISTICS

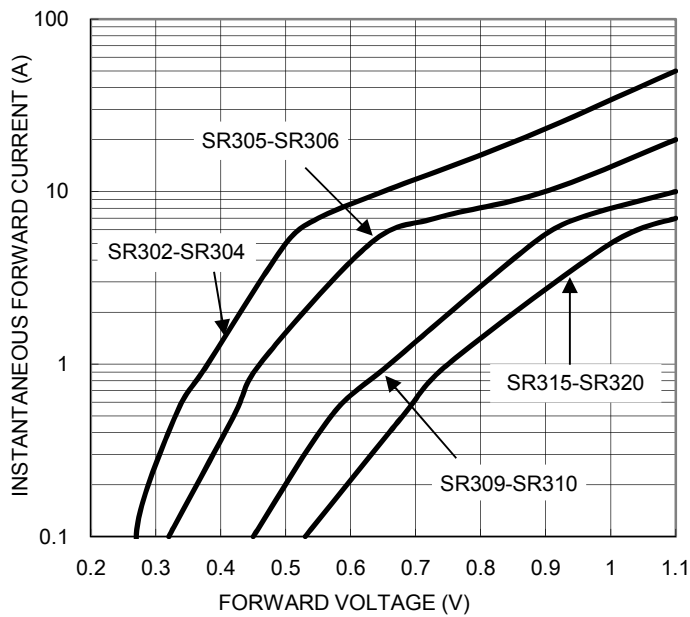

FIG. 4 TYPICAL REVERSE CHARACTERISTICS

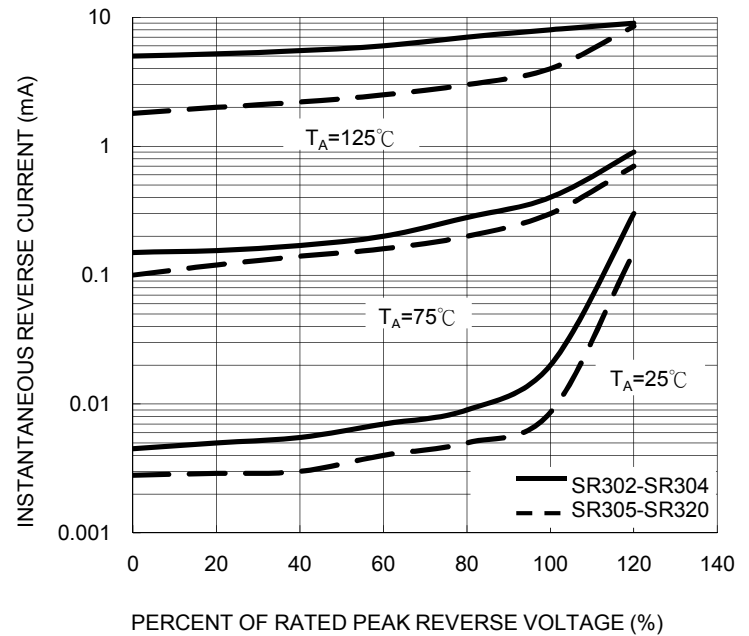

FIG. 5 TYPICAL JUNCTION CAPACITANCE

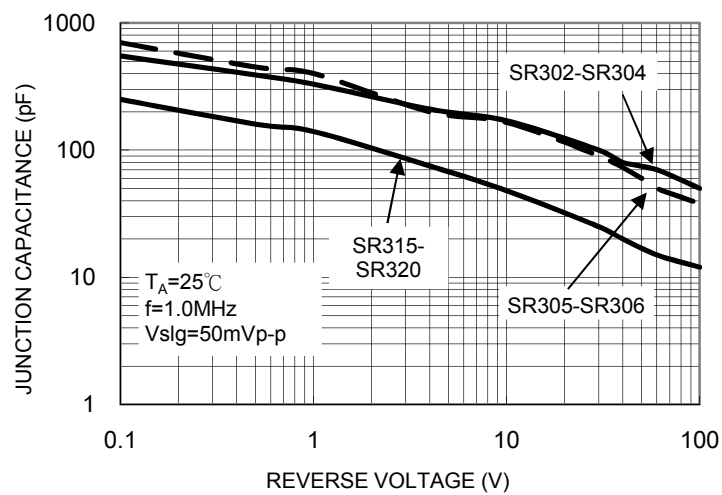
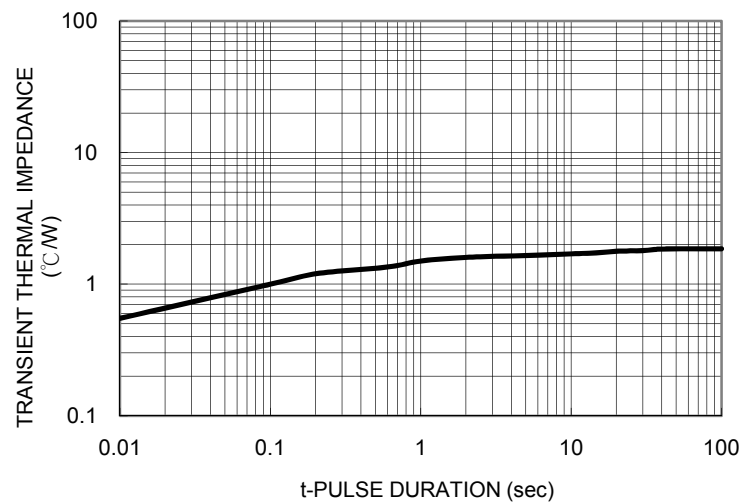

FIG. 6 TYPICAL TRANSIENT THERMAL IMPEDANCE



Ordering information

Part No.	Package	Packing	INNER TAPE	Packing code	Green Compound Packing code
SR3xx (Note)	DO-201AD	500 / AMMO box	52mm	A0	A0G
	DO-201AD	1.25K / 13" Reel	52mm	R0	R0G
	DO-201AD	500 / Bulk packing		B0	B0G
	DO-201AD	500 / Bulk packing		X0	X0G

Note: "xx" is Device Code from "02" thru "20".

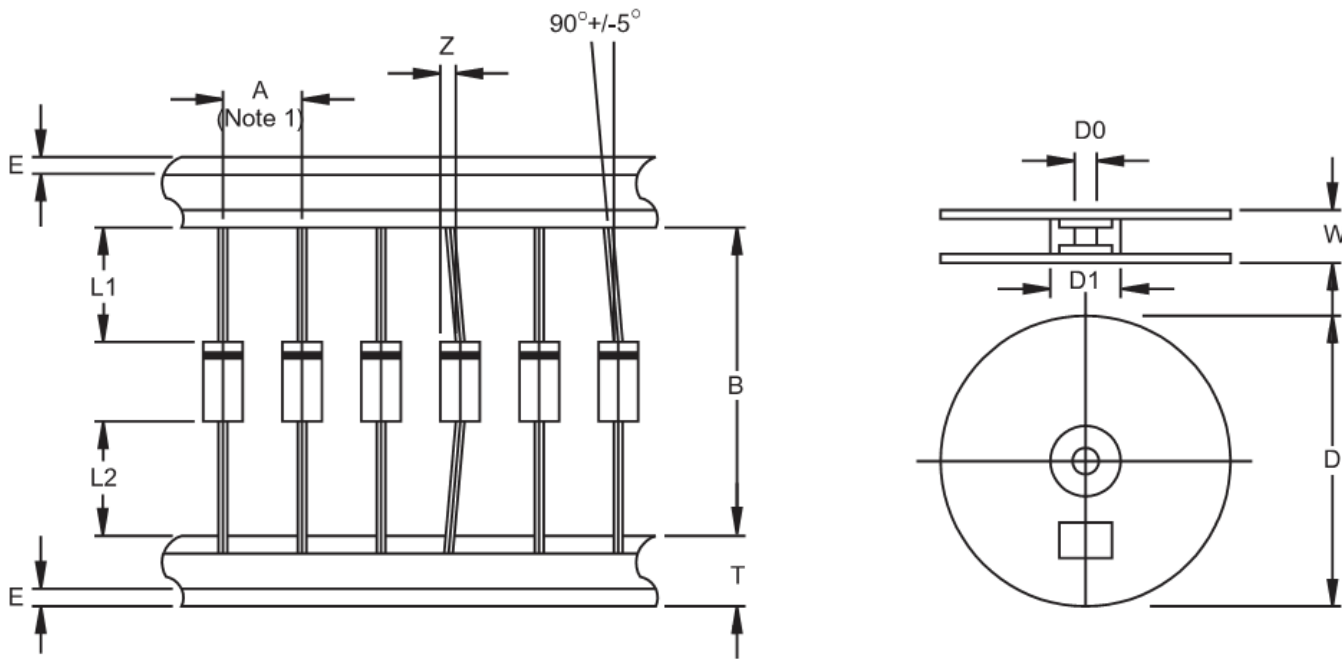
AXIAL LEAD TAPING SPECIFICATIONS

Outline	A	B	Z	T	E	L1-L2	D	D1	D0	W
	±0.5	±1.5	MAX	±0.4	MAX	MAX		±0.3	±0.4	±1.0
DO-201AD	10	52.4	1.2	6	0.8	1	330	85.7	16.6	76

Unit (mm)

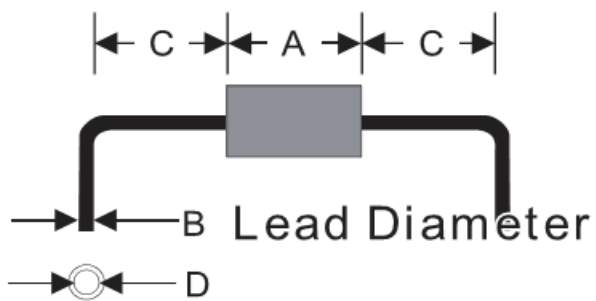
Suggested Mounting Hole Rule

Symbol	Unit(mm)
A	9.0
B	1.2
C	4.0
D	1.6

Dimensions

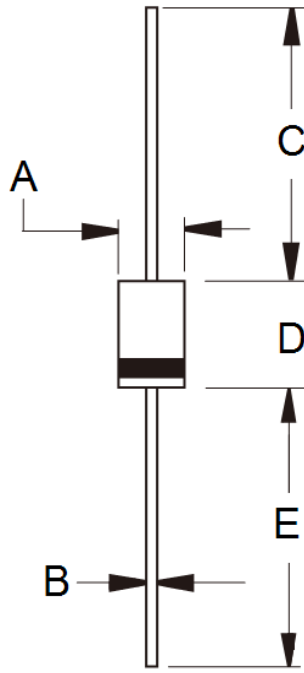

DIM.	Unit(mm)		Unit(inch)	
	Min	Max	Min	Max
A	5.00	5.60	0.197	0.220
B	1.20	1.30	0.048	0.052
C	25.40	-	1.000	-
D	8.50	9.50	0.335	0.375
E	25.40	-	1.000	-

Marking Diagram



- P/N = Specific Device Code
- G = Green Compound
- YWW = Date Code