

### Features

- ✧ For surface mounted application
- ✧ Easy pick and place
- ✧ Metal to silicon rectifier, majority carrier conduction
- ✧ Low power loss, high efficiency
- ✧ High current capability, low VF
- ✧ High surge current capability
- ✧ Meet MSL level 1, per J-STD-020D, lead free maximum peak of 260°C
- ✧ Plastic material used carriers Underwriters Laboratory Classfication 94V-0
- ✧ Epitaxial construction
- ✧ High temperature soldering guaranteed: 260°C/10s at terminals
- ✧ Green compound with suffix "G" on packing code & prefix "G" on datecode



### Mechanical Data

- ✧ Case: JEDEC SMA/DO-214AC Molded plastic
- ✧ Terminal: Pure tin plated, lead free
- ✧ Polarity: Indicated by cathode band
- ✧ Packaging: 12 mm tape per EIA STD RS-481
- ✧ Weight: 0.066 gram

### Ordering Information (example)

Part No.	Package	Packing	Packing code	Green Compound Packing code
SS12	SMA	1.8K / 7" REEL	R3	R3G

### Maximum Ratings and Electrical Characteristics

Rating at 25 °C ambient temperature unless otherwise specified.

Single phase, half wave, 60 Hz, resistive or inductive load.

For capacitive load, derate current by 20%

Type Number	Symbol	SS 12	SS 13	SS 14	SS 15	SS 16	SS 19	SS 110	SS 115	Unit
Maximum Repetitive Peak Reverse Voltage	$V_{RRM}$	20	30	40	50	60	90	100	150	V
Maximum RMS Voltage	$V_{RMS}$	14	21	28	35	42	63	70	105	V
Maximum DC Blocking Voltage	$V_{DC}$	20	30	40	50	60	90	100	150	V
Maximum Average Forward Rectified Current	$I_{F(AV)}$	1								A
Peak Forward Surge Current, 8.3 ms Single Half Sine-wave Superimposed on Rated Load (JEDEC method)	$I_{FSM}$	30								A
Maximum Instantaneous Forward Voltage (Note 1) $I_F = 1 A @ 25^\circ C$ $I_F = 1 A @ 100^\circ C$	$V_F$	0.5 0.4		0.75 0.65		0.80 0.70		0.95 0.85		V
Maximum Reverse Current @ Rated VR $T_A = 25^\circ C$ $T_A = 100^\circ C$ $T_A = 125^\circ C$	$I_R$	0.4				0.1				mA
		10		5		-				mA
		-		-		2				mA
Typical Junction Capacitance (Note 2)	$C_j$	50								pF
Typical Thermal Resistance	$R_{\theta JL}$	28								$^\circ C/W$
	$R_{\theta JA}$	88								
Operating Temperature Range	$T_J$	- 65 to + 125				- 65 to + 150				$^\circ C$
Storage Temperature Range	$T_{STG}$	- 65 to + 150								$^\circ C$

Note1: Pulse Test with PW=300u sec, 1% Duty Cycle

Note2: Measured at 1 MHz and Applied Reverse Voltage of 4.0V D.C.

RATINGS AND CHARACTERISTIC CURVES (SS12 THRU SS115)

FIG.1 FORWARD CURRENT DERATING CUURVE

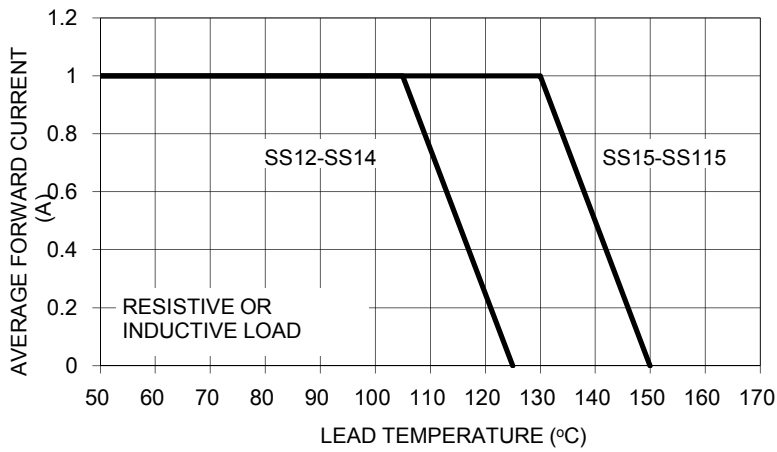

FIG. 2 MAXIMUM NON-REPETITIVE FORWARD SURGE CURRENT

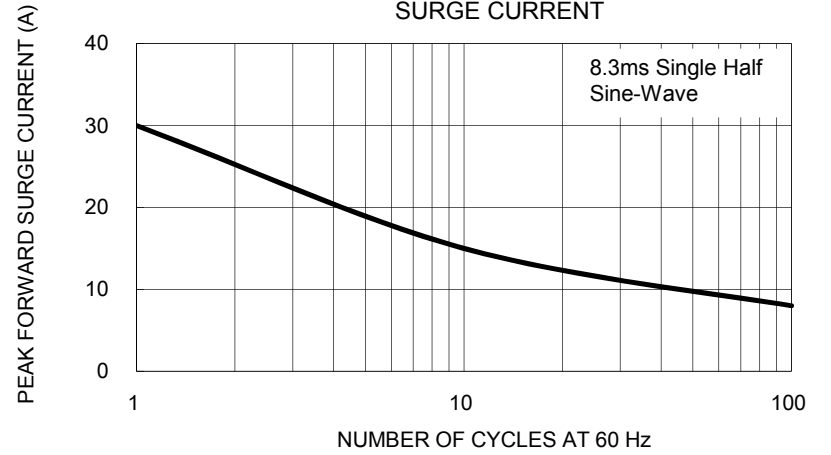

FIG. 3 TYPICAL FORWARD CHARACTERISTICS

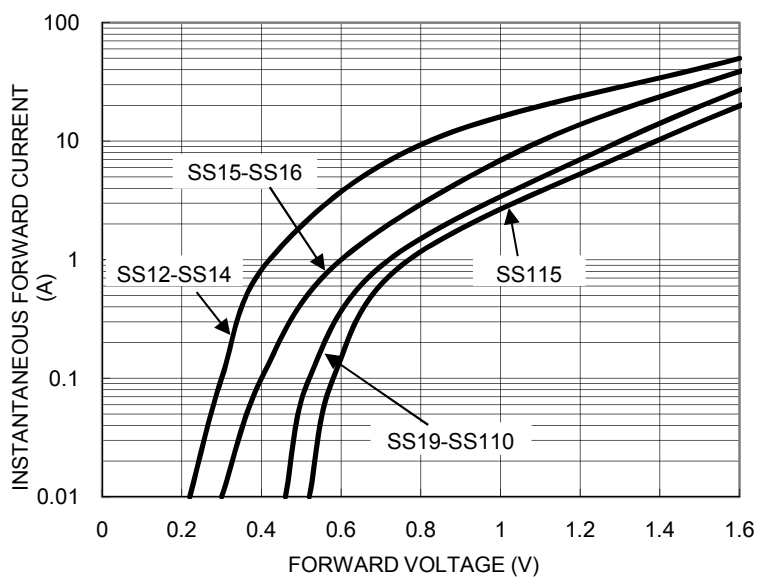

FIG. 4 TYPICAL REVERSE CHARACTERISTICS

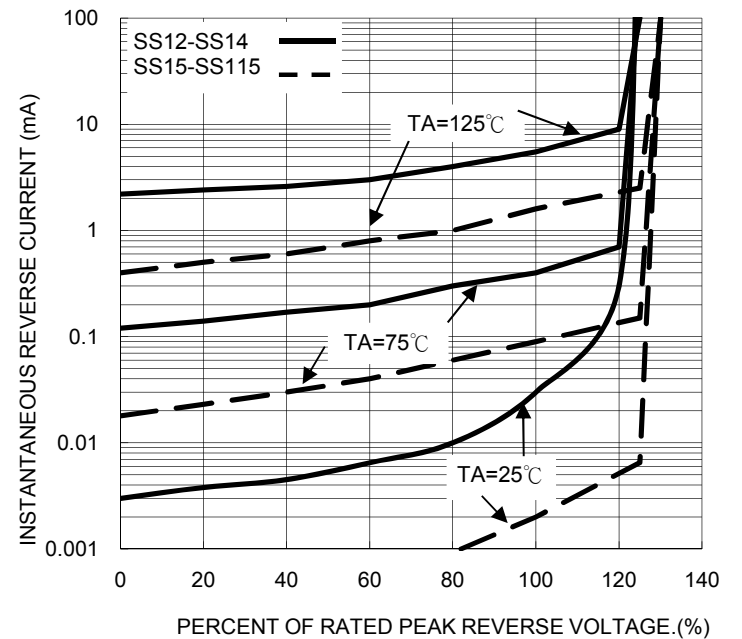

FIG. 5 TYPICAL JUNCTION CAPACITANCE

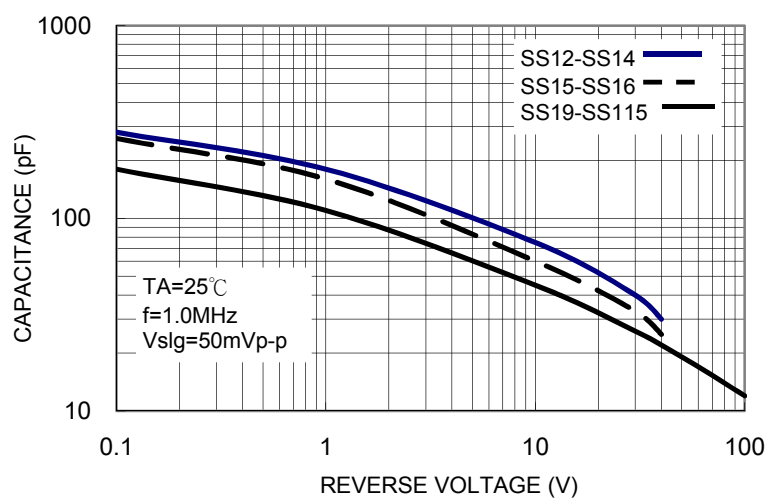
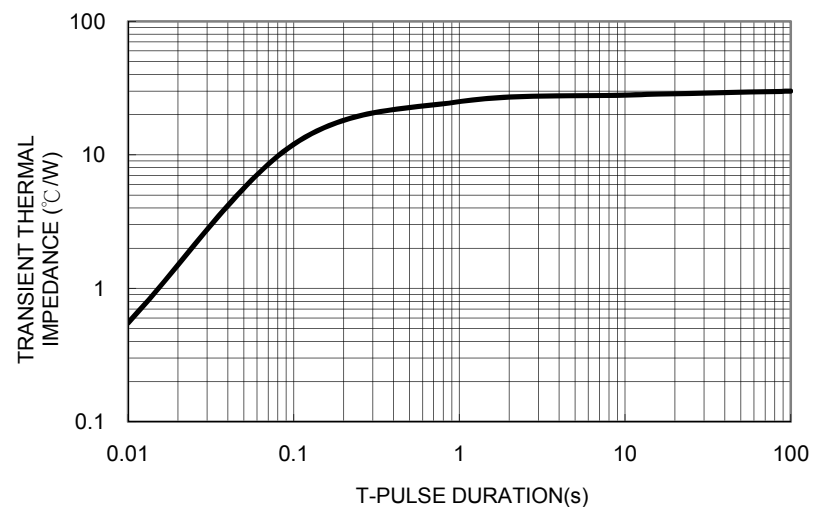

FIG. 6 TYPICAL TRANSIENT THERMAL IMPEDANCE



### Ordering information

Part No.	Package	Packing	Packing code	Green Compound Packing code
SS1X (Note)	SMA	1.8K / 7" REEL	R3	R3G
	SMA	7.5K / 13" REEL	R2	R2G
	Folded SMA	1.8K / 7" REEL	F3	F3G
	Folded SMA	7.5K / 13" REEL	F2	F2G
	C SMA	1.8K / 7" REEL	E3	E3G
	C SMA	7.5K / 13" REEL	E2	E2G

Note: "x" is Device Code from "2" thru "15".

### Tape & Reel specification

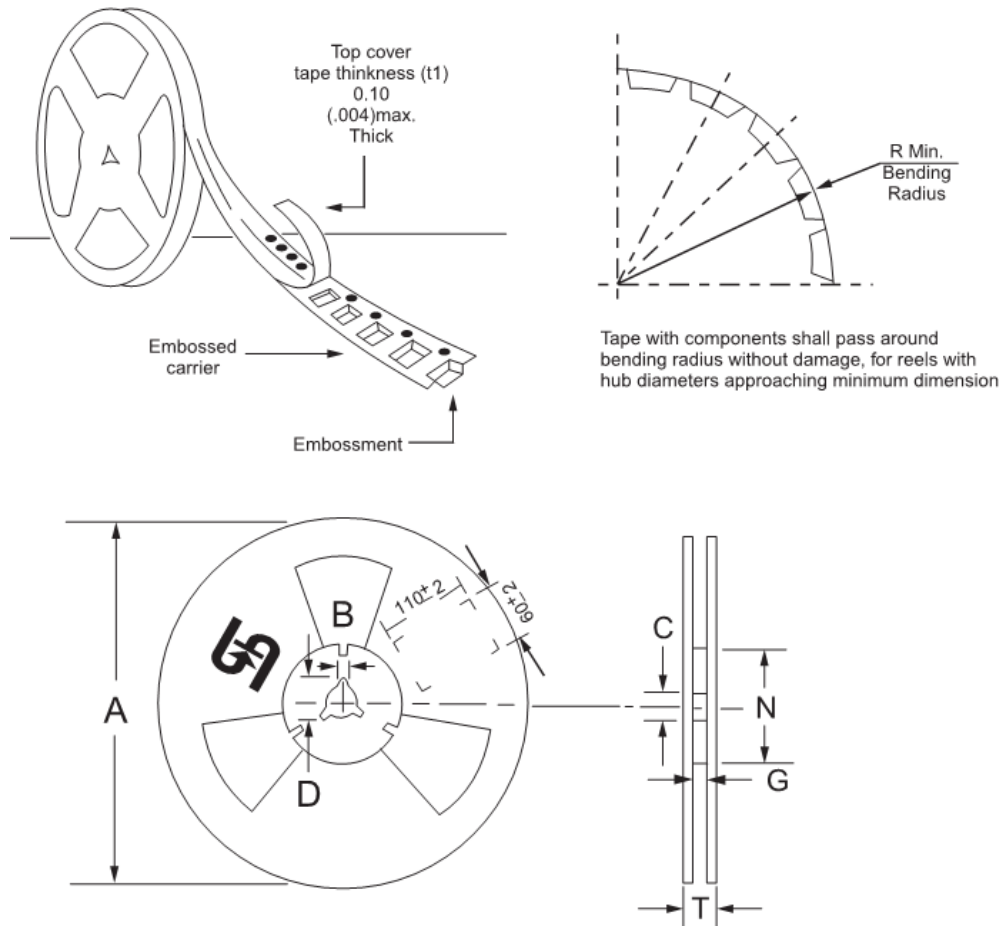

Reel Size	Tape Size	A	B	C	D	N	G	T
7"	12mm	±2.0	±0.4	+0.5;-0.2	min	±1.0	+0.8;-0	max
13"	12mm	max	±0.5	±0.5	min	±0.5	+2.0;-0	max
		178	1.9	13	21	62	12.2	14.6
		330	2	13	20.2	75	12.4	18.4

Unit (mm)

### Suggested PAD Layout

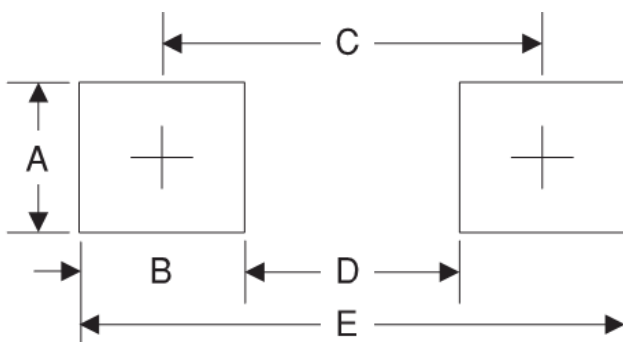

Symbol	Unit(mm)
A	1.78
B	1.51
C	3.92
D	2.41
E	4.43

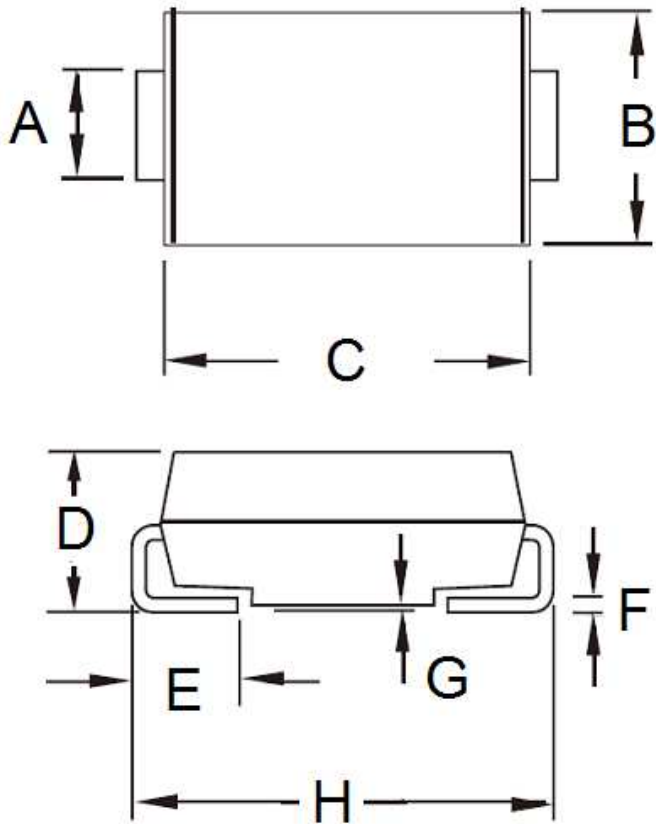
**Package Outline Dimensions**

DIM.	Unit(mm)		Unit(inch)	
	Min	Max	Min	Max
A	1.27	1.58	0.050	0.062
B	2.29	2.83	0.090	0.111
C	4.06	4.60	0.160	0.181
D	1.99	2.50	0.078	0.098
E	0.90	1.41	0.035	0.056
F	0.15	0.31	0.006	0.012
G	0.10	0.20	0.004	0.008
H	4.95	5.33	0.195	0.210

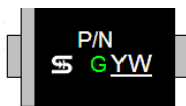
**Marking Diagram**

P/N = Specific Device Code  
 G = Green Compound  
 YW = Date Code