

Features

- ✧ Very low profile - typical height of 0.68mm
- ✧ Ideal for automated placement
- ✧ Low forward voltage drop. Low power loss.
- ✧ High efficiency
- ✧ Meet MSL level 1, per J-STD-020D, lead free maximum peak of 260°C
- ✧ Solder dip 265°C max. 10 s, per JESD 22-A111
- ✧ Compliant to RoHS directive 2002/95/EC and in accordance to WEEE 2002/96/EC
- ✧ Halogen-free according to IEC 61249-2-21 definition



Mechanical Data

- ✧ Case: Micro SMA
- ✧ Molding Compound meet UL 94V-0 rate flame flammability rating.
- ✧ Terminals: Matte tin plated leads, solderable per J-STD-002B, and JESD22-B102D
- ✧ Polarity: Indicated by Cathode Band
- ✧ Packaging: 8 mm tape per EIA Std RS-481
- ✧ Weight: 0.006 grams

Ordering Information (example)

Part No.	Package	Packing	Green Compound Packing code
SS13M	Mirco-SMA	3K / 7" REEL	RSG

Maximum Ratings and Electrical Characteristics

Rating at 25 °C ambient temperature unless otherwise specified.

Single phase, half wave, 60 Hz, resistive or inductive load.

For capacitive load, derate current by 20%

Type Number	Symbol	SS13M	SS14M	SS16M	Units
Device Marking Code		A	B	C	
Maximum Repetitive Peak Reverse Voltage	V_{RRM}	30	40	60	V
Maximum Average Forward Rectified Current	$I_{F(AV)}$	1			A
Peak Forward Surge Current, 8.3 ms Single Half Sine-wave Superimposed on Rated Load	I_{FSM}	25			A
Maximum Instantaneous Forward Voltage (Note 1) @ 0.5A / TA=25 °C @ 0.5A / TA=125 °C @ 1.0A / TA=25 °C @ 1.0A / TA=125 °C	V_F	TYP.	MAX.	TYP.	MAX.
		0.45	-	0.51	-
		0.35	-	0.46	-
		0.52	0.55	0.64	0.68
Maximum Reverse Current @ TA=25 °C @ TA=125 °C @ TA=150 °C	I_R	TYP.	MAX.	TYP.	MAX.
		5	50	5	50
		3	10	3	10
Typical Junction Capacitance (Note 2)	C_j	50		40	pF
Typical Thermal Resistance	$R_{\theta JA}$	125			°C/W
	$R_{\theta JL}$	30			
	$R_{\theta JC}$	40			
Operating Temperature Range	T_J	-55 to + 150			°C
Storage Temperature Range	T_{STG}	-55 to + 150			°C

Note1: Pulse Test with PW=300 usec, 1% Duty Cycle

Note2: Measured at 1 MHz and Applied Reverse Voltage of 4.0 V D.C.

RATINGS AND CHARACTERISTIC CURVES (SS13M THRU SS16M)

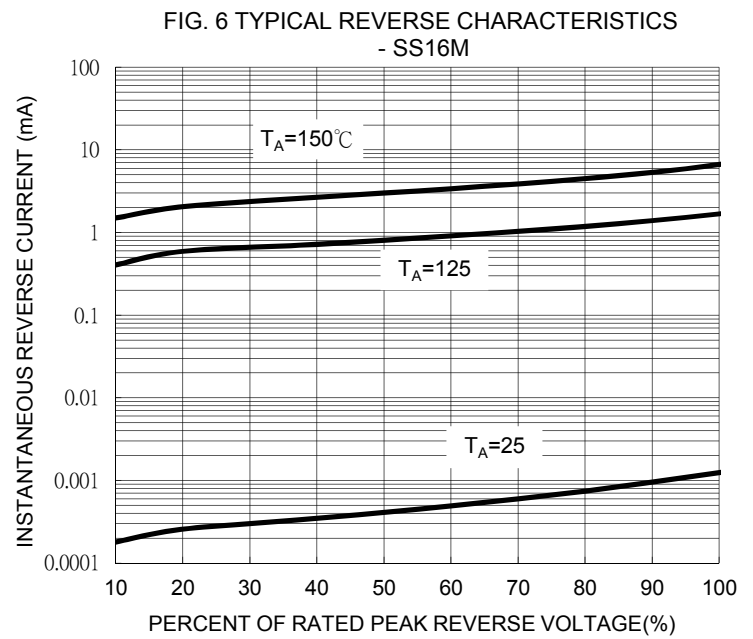
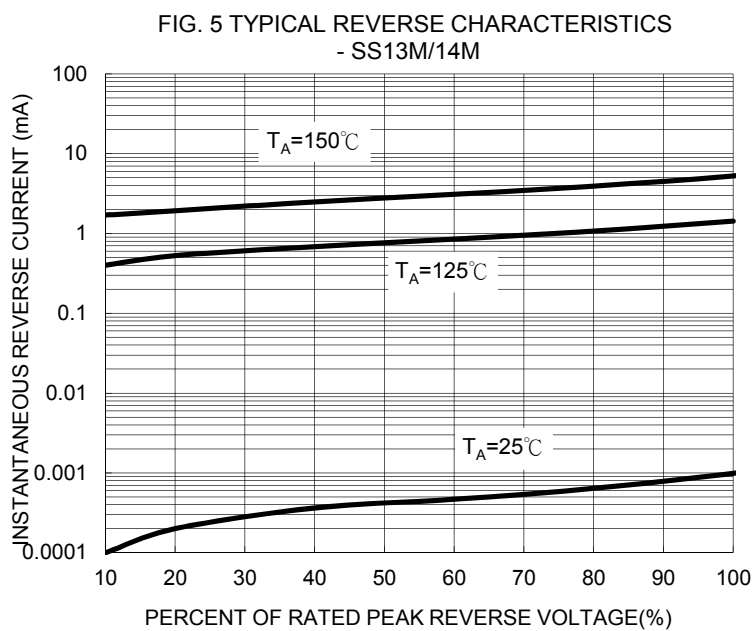
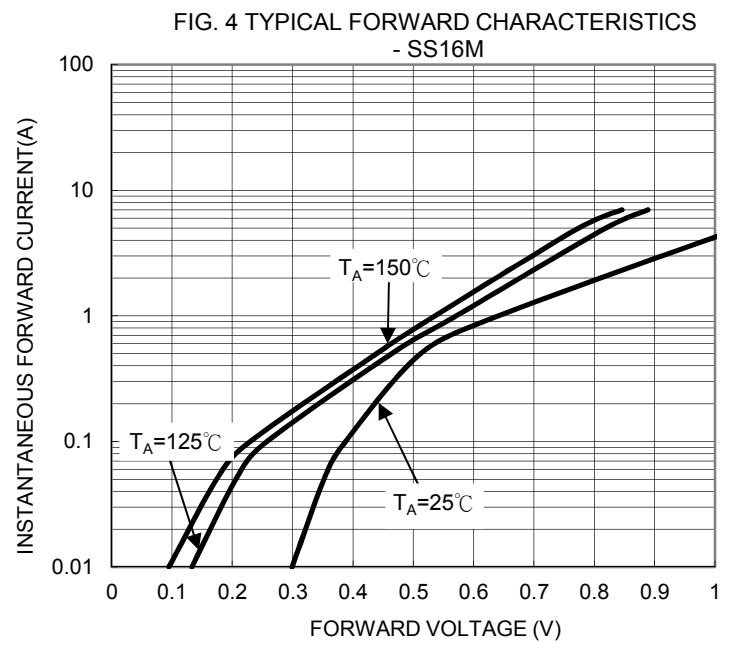
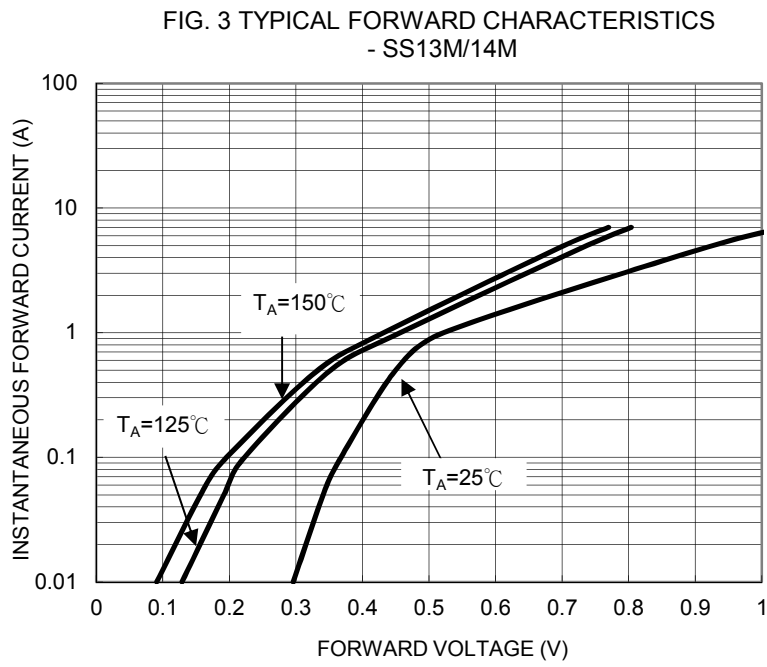
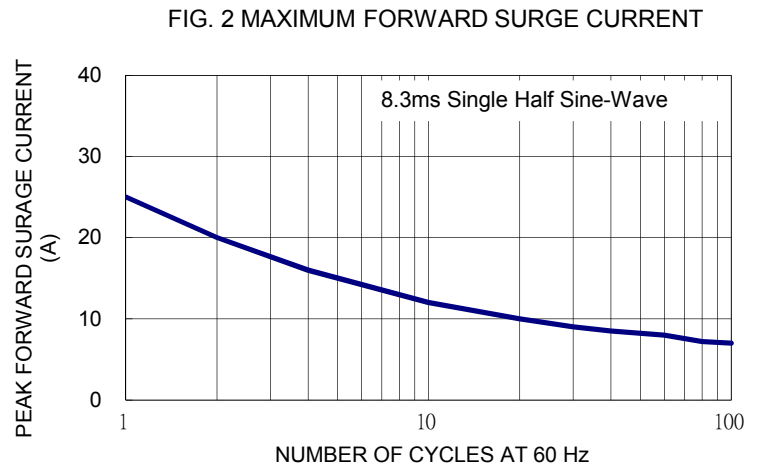
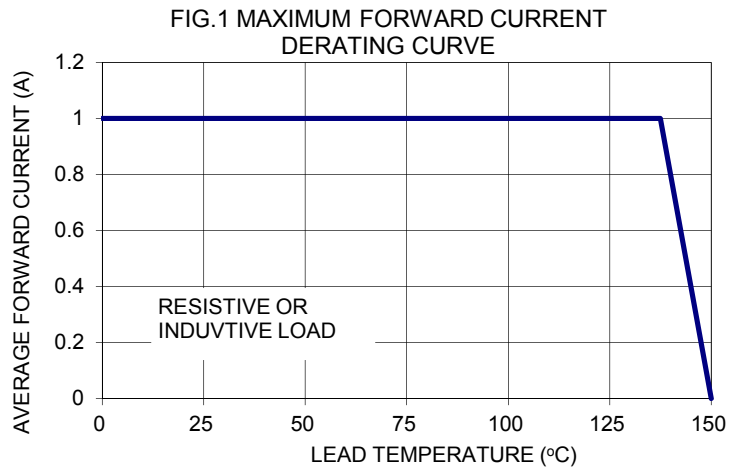

RATINGS AND CHARACTERISTIC CURVES (SS13M THRU SS16M)

FIG. 7 TYPICAL JUNCTION CAPACITANCE

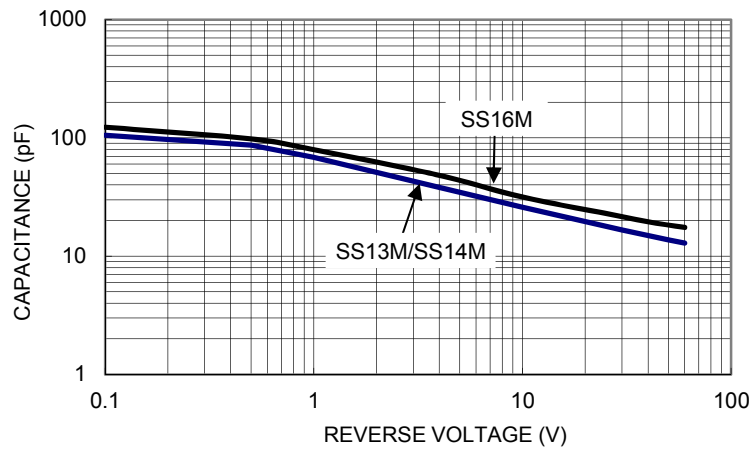
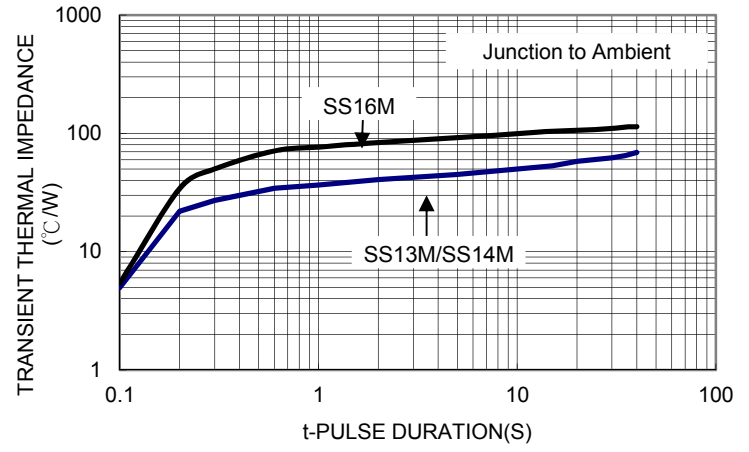

FIG. 8 TYPICAL TRANSIENT THERMAL IMPEDANCE



Ordering information

Part No.	Package	Packing	Green Compound Packing code
SS13M	Mirco-SMA	3K / 7" REEL	RSG
SS14M	Mirco-SMA	3K / 7" REEL	RSG
SS16M	Mirco-SMA	3K / 7" REEL	RSG

Tape & Reel specification

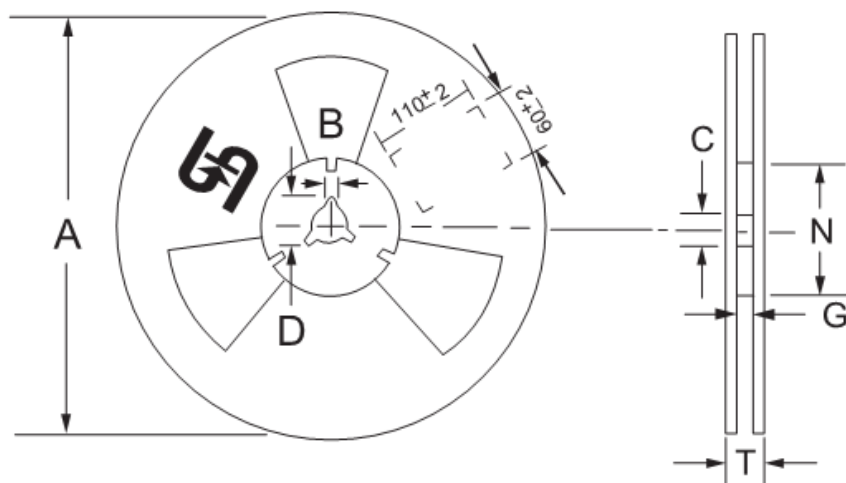
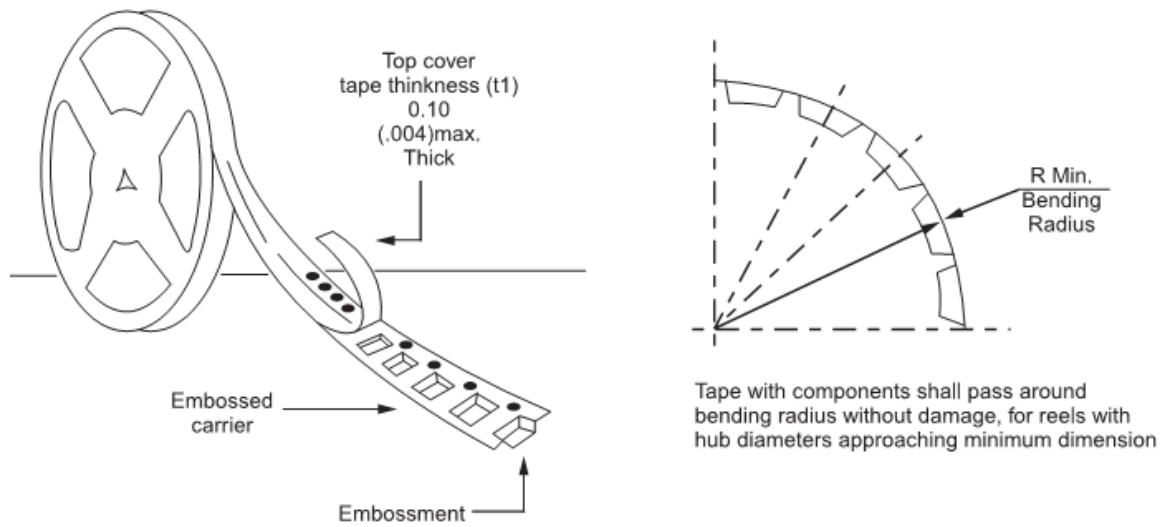

Symbol	Dimension (mm)	
A	178	±2
B	1.9	±0.4
C	13	+0.5/-0.2
D	21	MIN
N	62	±1.0
G	8.2	+0.8/-0
T	10.6	MAX

Suggested PAD Layout



Symbol	Unit(inch)	Unit(mm)
A	0.043	1.1
B	0.079	2
C	0.02	0.5
D	0.032	0.8
E	0.039	1

Package Outline Dimensions

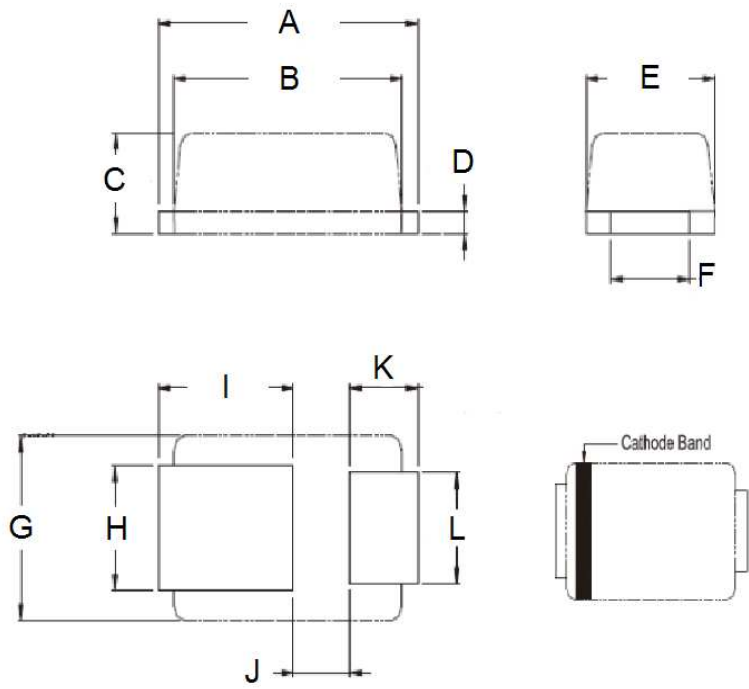

DIM.	Unit(mm)		Unit(inch)	
	Min	Max	Min	Max
A	2.30	2.70	0.091	0.106
B	2.10	2.30	0.083	0.091
C	0.63	0.73	0.025	0.029
D	0.10	0.20	0.004	0.008
E	1.15	1.35	0.045	0.053
F	0.65	0.85	0.026	0.034
G	1.15	1.35	0.045	0.053
H	0.75	0.95	0.030	0.037
I	1.10	1.50	0.043	0.059
J	0.55	0.75	0.022	0.030
K	0.55	0.75	0.022	0.030
L	0.65	0.85	0.026	0.034

Marking Diagram



P =Device Name Code
YW =Date Code