

## Features

- ✧ For surface mounted application
- ✧ Easy pick and place
- ✧ Metal to silicon rectifier, majority carrier conduction
- ✧ Low power loss, high efficiency
- ✧ High current capability, low VF
- ✧ High surge current capability
- ✧ Plastic material used carriers Underwriters Laboratory Classification 94V-0
- ✧ Meet MSL level 1, per J-STD-020D, lead free maximum peak of 260°C
- ✧ Epitaxial construction
- ✧ High temperature soldering: 260°C/10 seconds at terminals
- ✧ Green compound with suffix "G" on packing code & prefix "G" on datecode.



## Mechanical Data

- ✧ Case: Molded plastic
- ✧ Terminals: Pure tin plated, lead free.
- ✧ Polarity: Indicated by cathode band
- ✧ Packaging: 12mm tape per EIA STD RS-481
- ✧ Weight: 0.093 grams

## Ordering Information (example)

Part No.	Package	Packing	Packing code	Green Compound Packing code
SS22	SMB	850 / 7" REEL	R5	R5G

## Maximum Ratings and Electrical Characteristics

Rating at 25 °C ambient temperature unless otherwise specified.

Single phase, half wave, 60 Hz, resistive or inductive load.

For capacitive load, derate current by 20%

Type Number	Symbol	SS 22	SS 23	SS 24	SS 25	SS 26	SS 29	SS 210	SS 215	Units	
Maximum Recurrent Peak Reverse Voltage	$V_{RRM}$	20	30	40	50	60	90	100	150	V	
Maximum RMS Voltage	$V_{RMS}$	14	21	28	35	42	63	70	105	V	
Maximum DC Blocking Voltage	$V_{DC}$	20	30	40	50	60	90	100	150	V	
Maximum Average Forward Rectified Current	$I_{F(AV)}$	2								A	
Peak Forward Surge Current, 8.3 ms Single Half Sine-wave Superimposed on Rated Load (JEDEC method)	$I_{FSM}$	50								A	
Maximum Instantaneous Forward Voltage (Note 1) $I_F = 2\text{ A}$ @ 25 °C @ 100 °C	$V_F$	0.5 0.4		0.70 0.65		0.85 0.70		0.95 0.80		V	
Maximum DC Reverse Current at Rated DC Blocking Voltage @ $T_A = 25\text{ °C}$ @ $T_A = 100\text{ °C}$ @ $T_A = 125\text{ °C}$	$I_R$	0.4					0.1				mA
		10			5		-				mA
		-					5.0				mA
Typical Junction Capacitance (Note 2)	$C_j$	130								pF	
Typical Thermal Resistance	$R_{\theta JL}$	17								°C/W	
	$R_{\theta JA}$	75									
Operating Temperature Range	$T_J$	- 65 to + 125				- 65 to + 150				°C	
Storage Temperature Range	$T_{STG}$	- 65 to + 150									°C

Note 1: Pulse Test with PW=300u sec, 1% Duty Cycle

Note 2: Measure at 1MHz and Applied Reverse Voltage of 4.0V D.C.

RATINGS AND CHARACTERISTIC CURVES (SS22 THRU SS215)

FIG.1- MAXIMUM FORWARD CURRENT DERATING CURVE

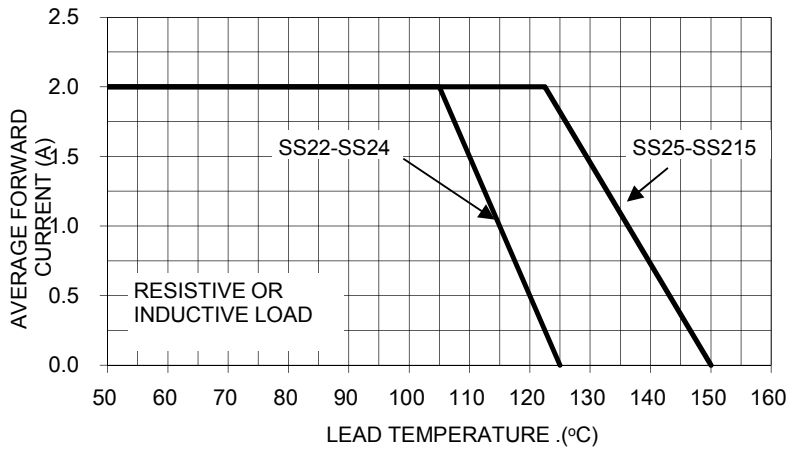

FIG. 2- MAXIMUM NON-REPETITIVE FORWARD SURGE CURRENT

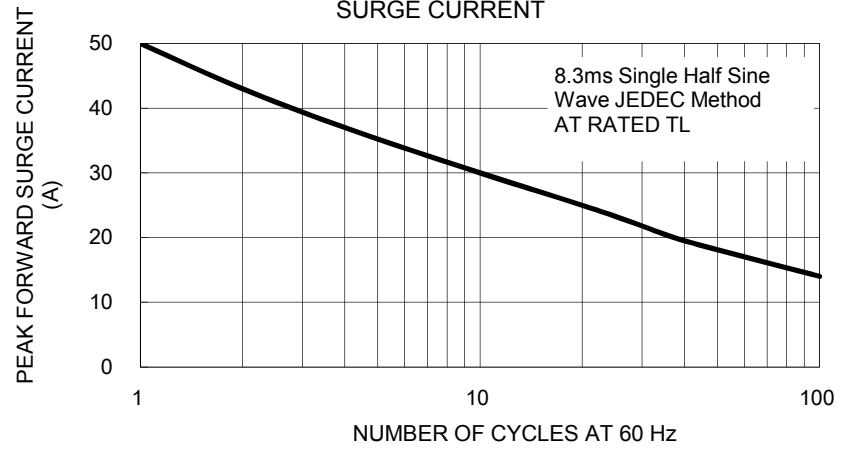

FIG. 3- TYPICAL FORWARD CHARACTERISTICS

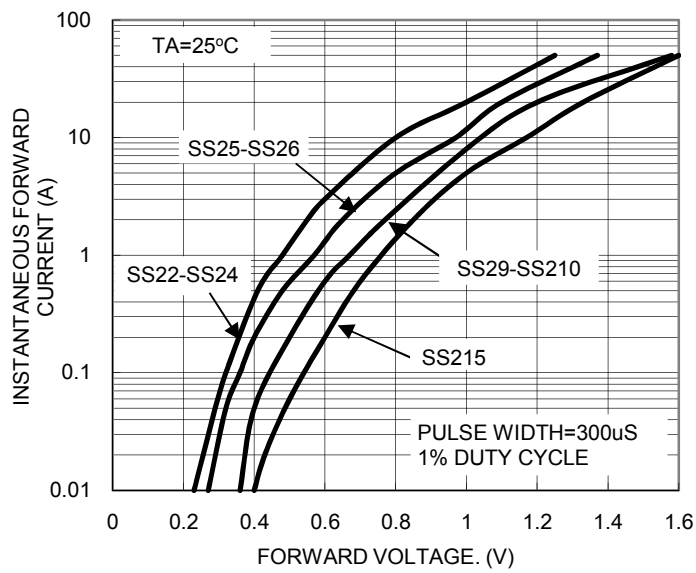

FIG. 4- TYPICAL REVERSE CHARACTERISTICS

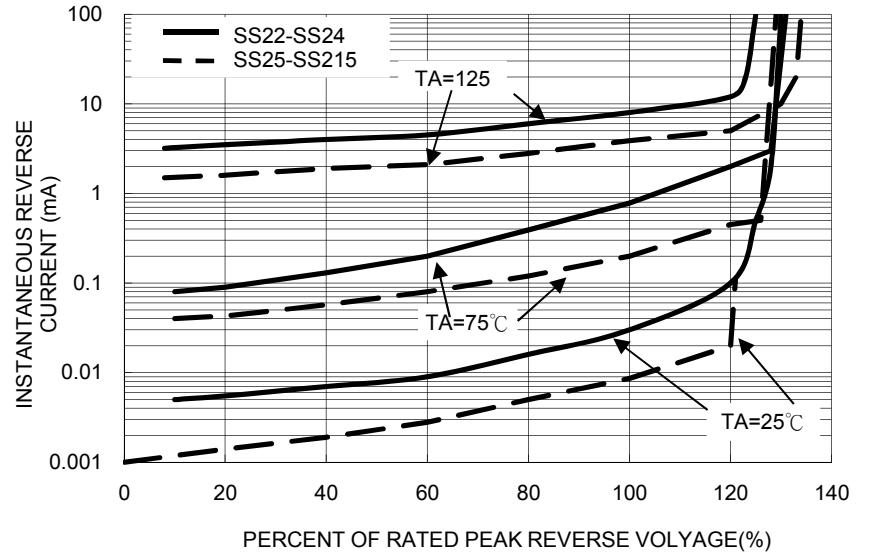

FIG. 5- TYPICAL JUNCTION CAPACITANCE

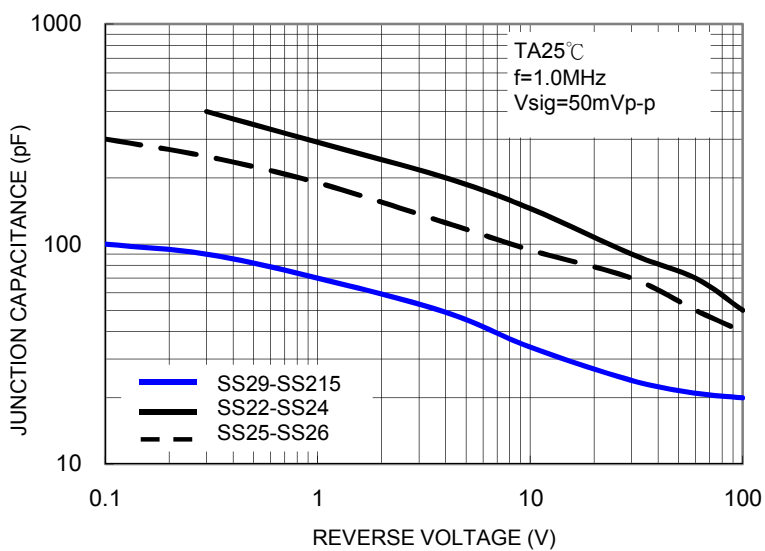
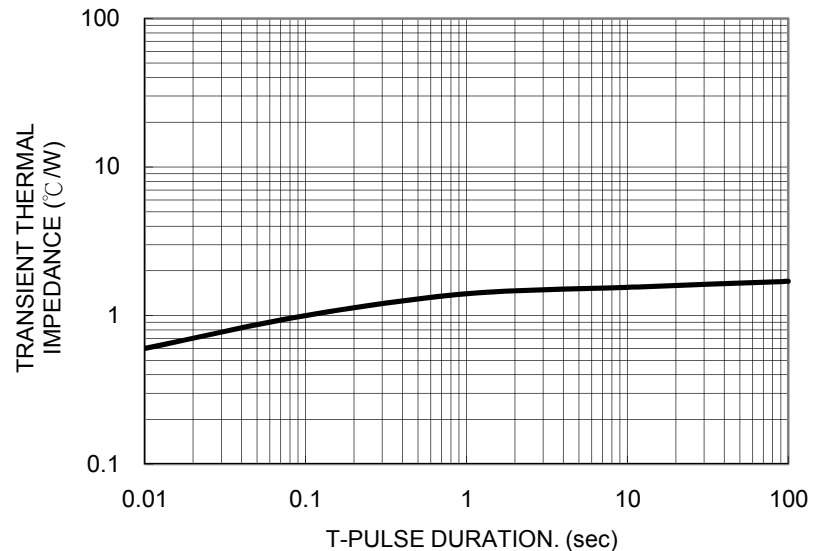

FIG. 6- TYPICAL TRANSIENT THERMAL CHARACTERISTICS



### Ordering information

Part No.	Package	Packing	Packing code	Green Compound Packing code
SS2x (Note)	SMB	850 / 7" REEL	R5	R5G
	SMB	3K / 13" REEL	R4	R4G
	SMB	3K / 13" REEL	M4	M4G

Note: "x" is Device Code from "2" thru "15".

### Tape & Reel specification

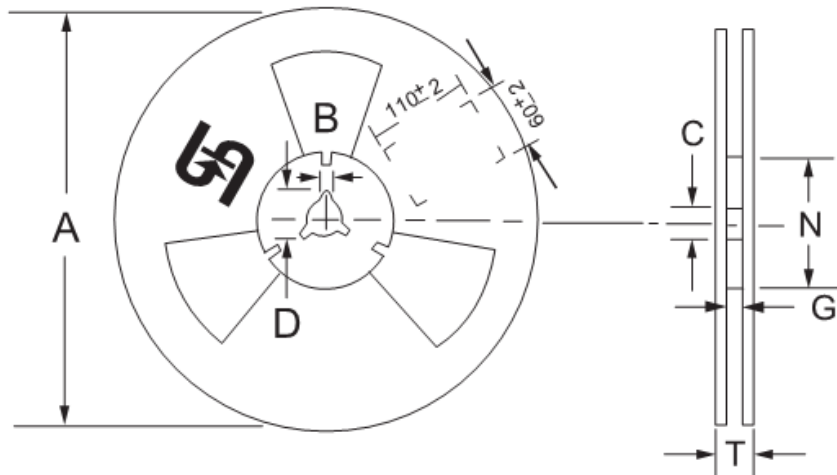
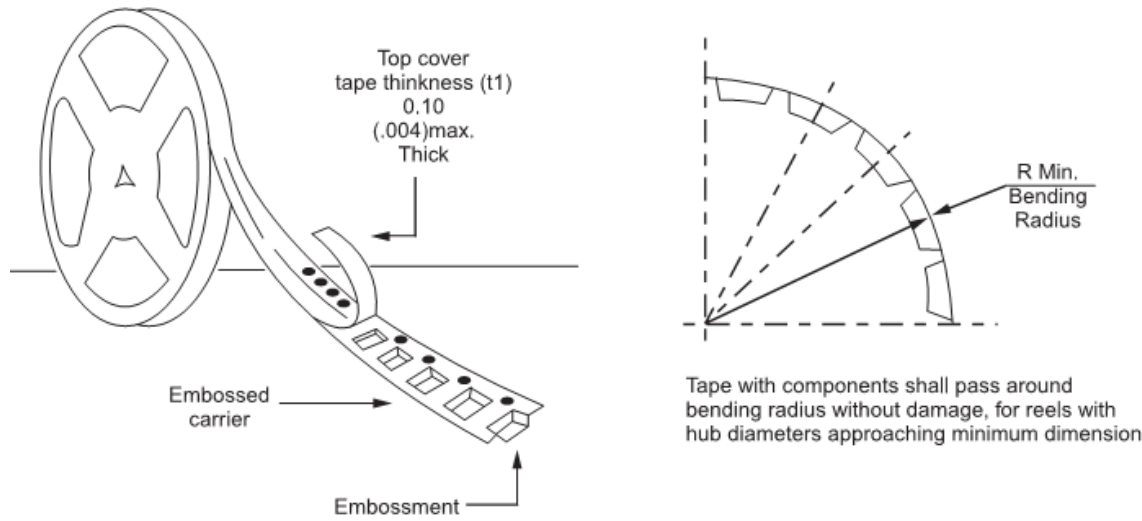

Reel Size	Tape Size	A	B	C	D	N	G	T
		±2.0	±0.4	+0.5;-0.2	min	±1.0	+0.8;-0	max
7"	12mm	178	1.9	13	21	62	12.2	14.6
Reel Size	Tape Size	A	B	C	D	N	G	T
		max	±0.5	±0.5	min	±0.5	+2.0;-0	max
13"	12mm	330	2	13	20.2	75	12.4	18.4

Unit (mm)

### Suggested PAD Layout

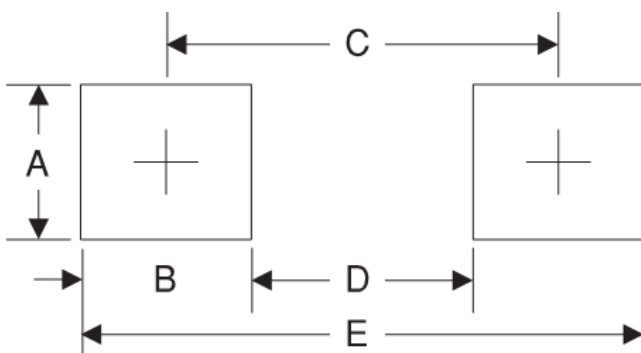

Symbol	Unit(mm)
A	2.3
B	2.5
C	4.3
D	1.8
E	6.7

**Dimensions**

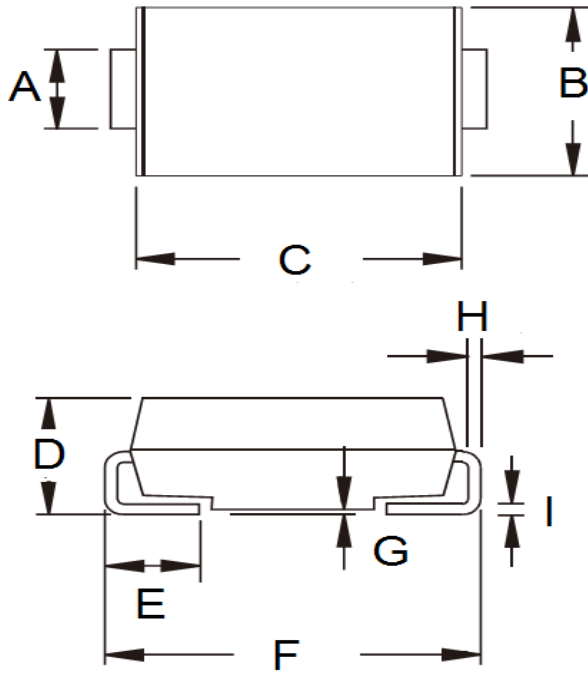

DIM.	Unit(mm)		Unit(inch)	
	Min	Max	Min	Max
A	1.95	2.10	0.077	0.083
B	3.48	3.73	0.137	0.147
C	4.25	4.75	0.167	0.187
D	1.99	2.61	0.078	0.103
E	0.90	1.41	0.035	0.056
F	5.10	5.30	0.201	0.209
G	0.10	0.20	0.004	0.008
H	0.15	0.31	0.006	0.012
I	0.15	0.31	0.006	0.012

**Marking Diagram**

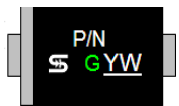

- P/N = Specific Device Code
- G = Green Compound
- YW = Date Code