

### Features

- ◇ Glass passivated chip junction
- ◇ High efficiency, Low VF
- ◇ High current capability
- ◇ High reliability
- ◇ High surge current capability
- ◇ Low power loss
- ◇ Green compound with suffix "G" on packing code & prefix "G" on datecode



### Mechanical Data

- ◇ Cases: Molded plastic
- ◇ Epoxy: UL 94V-0 rate flame retardant
- ◇ Lead: Pure tin plated, lead free, solderable per MIL-STD-202, Method 208 guaranteed
- ◇ Polarity: Color band denotes cathode
- ◇ High temperature soldering guaranteed: 260°C/10s /1.375", (9.5mm) lead lengths at 5 lbs, (2.3kg) tension
- ◇ Weight: 1.65 grams

### Ordering Information (example)

Part No.	Package	Packing	INNER TAPE	Packing code	Green Compound Packing code
6A05G	R-6	700 / AMMO box	52mm	A0	A0G

### Maximum Ratings and Electrical Characteristics

Rating at 25 °C ambient temperature unless otherwise specified.

Single phase, half wave, 60 Hz, resistive or inductive load.

For capacitive load, derate current by 20%

Type Number	Symbol	6A 05G	6A 10G	6A 20G	6A 40G	6A 60G	6A 80G	6A 100G	Units
Maximum Recurrent Peak Reverse Voltage	$V_{RRM}$	50	100	200	400	600	800	1000	V
Maximum RMS Voltage	$V_{RMS}$	35	70	140	280	420	560	700	V
Maximum DC Blocking Voltage	$V_{DC}$	50	100	200	400	600	800	1000	V
Maximum Average Forward Rectified Current	$I_{F(AV)}$	6							A
Peak Forward Surge Current, 8.3 ms Single Half Sine-wave Superimposed on Rated Load (JEDEC method)	$I_{FSM}$	250							A
Maximum Instantaneous Forward Voltage (Note 1) @ 6 A	$V_F$	1.1		1.0					V
Maximum DC Reverse Current at @ $T_A=25^\circ\text{C}$	$I_R$	10							uA
Rated DC Blocking Voltage @ $T_A=125^\circ\text{C}$		100							uA
Typical Junction Capacitance (Note 2)	$C_j$	60							pF
Typical Thermal Resistance	$R_{\theta JA}$	35							$^\circ\text{C/W}$
Operating and Storage Temperature Range	$T_J, T_{STG}$	- 65 to + 150							$^\circ\text{C}$

Note1: Pulse Test with PW=300 usec, 1% Duty Cycle

Note2: Measured at 1 MHz and Applied Reverse Voltage of 4.0V D.C.

RATINGS AND CHARACTERISTIC CURVES (6A05G THRU 6A100G)

FIG. 1- MAXMUM FORWARD CURRENT DERATING CURVE

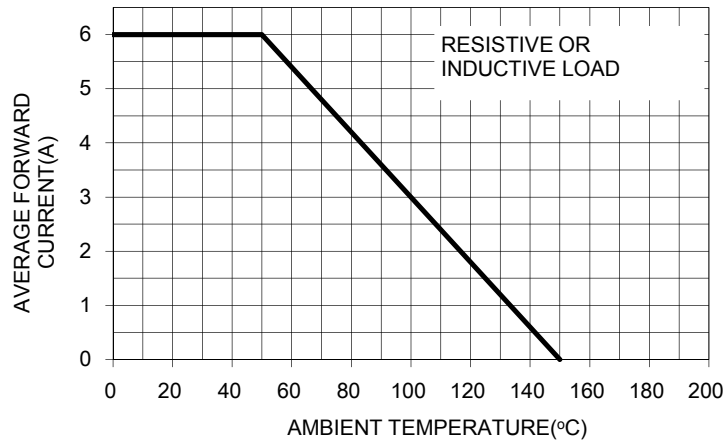

FIG. 2- TYPICAL REVERSE CHARACTERISTICS

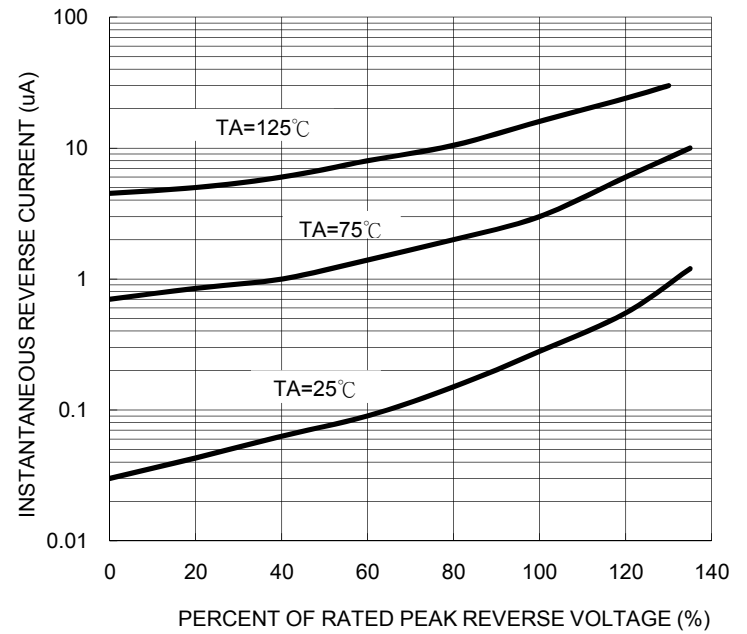

FIG. 3- MAXIMUM NON-REPETITIVE FORWARD SURGE CURRENT

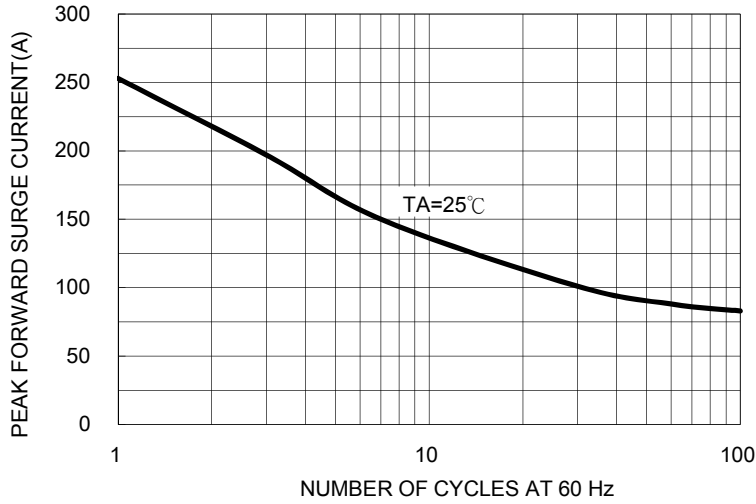

FIG. 5- TYPICAL FORWARD CHARACTERISTICS

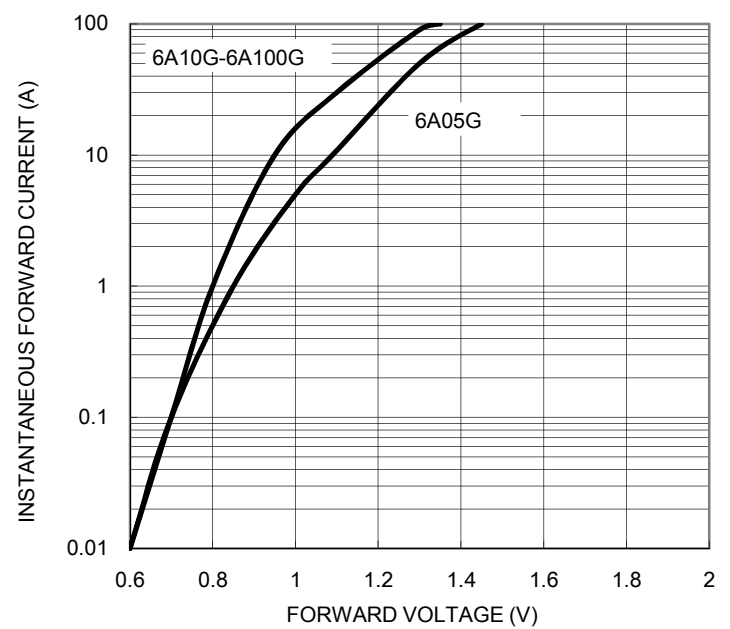
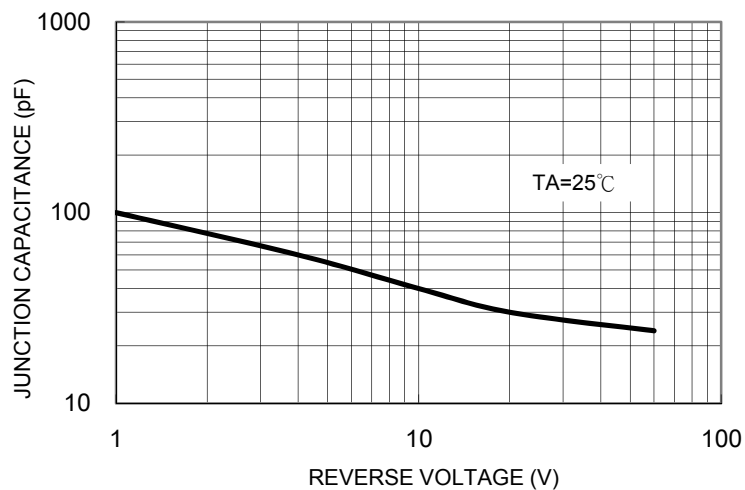

FIG. 4- TYPICAL JUNCTION CAPACITANCE



**Ordering information**

Part No.	Package	Packing	INNER TAPE	Packing code	Green Compound Packing code
6AxxG (Note)	R-6	700 / AMMO box	52mm	A0	A0G
	R-6	1 K / 13" Reel	52mm	R0	R0G
	R-6	400 / Bulk packing		B0	B0G

Note: "xx" is Device Code from "05" thru "100".

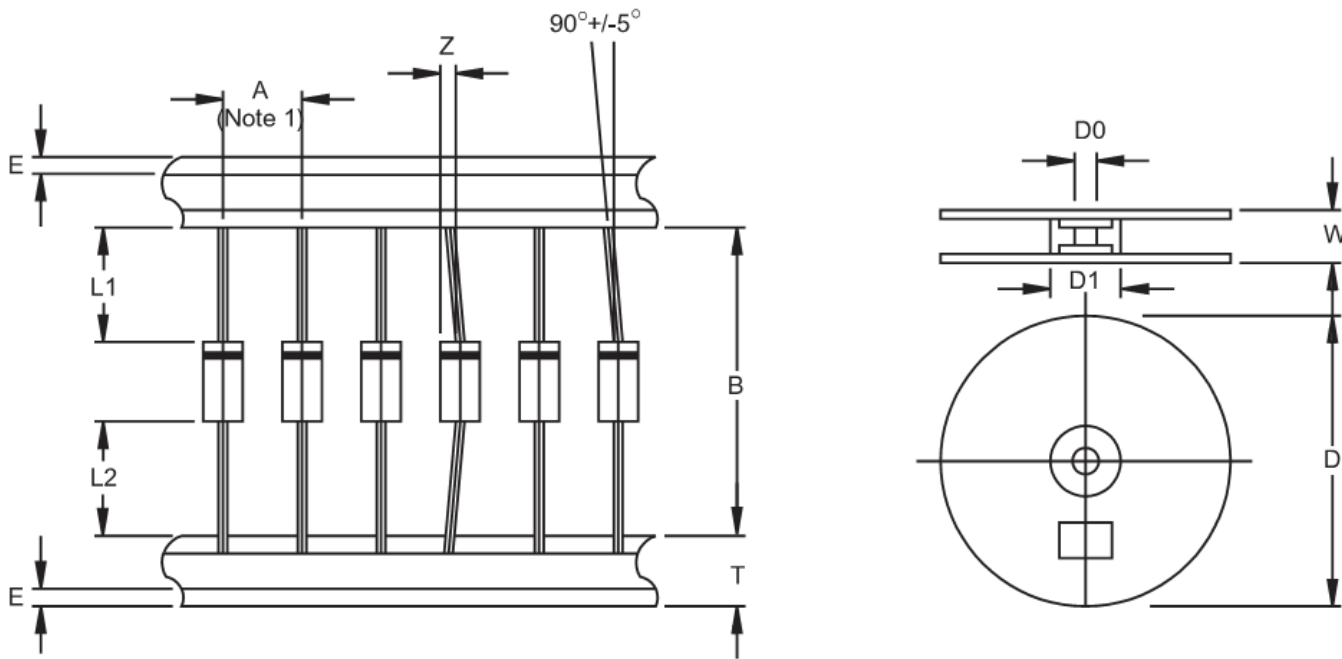
**AXIAL LEAD TAPING SPECIFICATIONS**

Outline	A	B	Z	T	E	L1-L2	D	D1	D0	W
	±0.5	±1.5	MAX	±0.4	MAX	MAX		±0.3	±0.4	±1.0
R-6	10	52.4	1.2	6	0.8	1	330	85.7	16.6	76

Unit (mm)

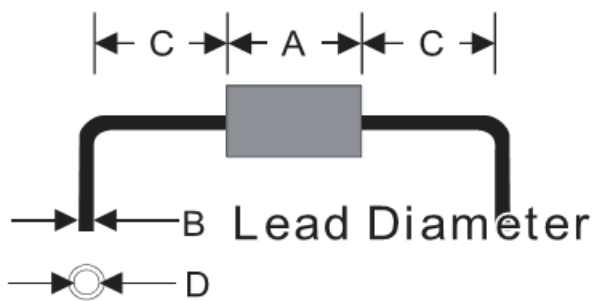
**Suggested Mounting Hole Rule**

Symbol	Unit(mm)
A	8.9
B	1.3
C	4.0
D	1.5

**Dimensions**

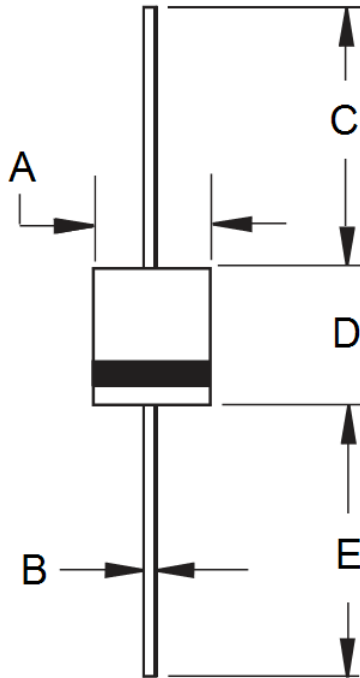

DIM.	Unit(mm)		Unit(inch)	
	Min	Max	Min	Max
A	6.80	7.20	0.268	0.283
B	1.20	1.30	0.047	0.051
C	25.40	-	1.000	-
D	8.60	9.10	0.339	0.358
E	25.40	-	1.000	-

**Marking Diagram**



- P/N = Specific Device Code
- G = Green Compound
- YWW = Date Code