

### Features

- ✧ UL Recognized File # E-326243
- ✧ For surface mounted application
- ✧ Glass passivated junction chip
- ✧ Low-Profile Package
- ✧ Ideal for automated placement
- ✧ Low power loss, high efficiency
- ✧ High temperature soldering:  
260°C/10 seconds at terminals
- ✧ Green compound with suffix "G" on packing code & prefix "G" on datecode



### Mechanical Data

- ✧ Case: Sub SMA plastic case
- ✧ Terminal: Pure tin plated, lead free
- ✧ Polarity: Color band denotes cathode
- ✧ Packaging: 8mm / 12mm tape per EIA STD RS-481
- ✧ Weight: 0.0196 grams
- ✧ Marking code refer to below specified

### Ordering Information (example)

Part No.	Package	Packing	Packing code	Green Compound Packing code
S1AL	Sub-SMA	3K / 7" REEL	RV	RVG

### Maximum Ratings and Electrical Characteristics

Rating at 25 °C ambient temperature unless otherwise specified.

Single phase, half wave, 60 Hz, resistive or inductive load.

For capacitive load, derate current by 20%

Type Number	Symbol	S1AL	S1BL	S1DL	S1GL	S1JL	S1KL	S1ML	Units
Maximum Recurrent Peak Reverse Voltage	$V_{RRM}$	50	100	200	400	600	800	1000	V
Maximum RMS Voltage	$V_{RMS}$	35	70	140	280	420	560	700	V
Maximum DC Blocking Voltage	$V_{DC}$	50	100	200	400	600	800	1000	V
Maximum Average Forward Rectified Current	$I_{F(AV)}$	1.0							A
Peak Forward Surge Current, 8.3 ms Single Half Sine-wave Superimposed on Rated Load (JEDEC method)	$I_{FSM}$	30							A
Maximum Instantaneous Forward Voltage (Note 1) @ 1 A	$V_F$	1.1							V
Maximum DC Reverse Current at @ $T_A=25\text{ }^\circ\text{C}$	$I_R$	5							$\mu\text{A}$
Rated DC Blocking Voltage @ $T_A=125\text{ }^\circ\text{C}$		50							$\mu\text{A}$
Typical Junction Capacitance (Note 2)	$C_j$	9							pF
Typical Reverse Recovery Time (Note 3)	$T_{rr}$	1.8							$\mu\text{S}$
Typical Thermal Resistance	$R_{\theta JL}$	25					30		$^\circ\text{C/W}$
	$R_{\theta JA}$	85					85		
Operating Temperature Range	$T_J$	- 55 to + 175							$^\circ\text{C}$
Storage Temperature Range	$T_{STG}$	- 55 to + 175							$^\circ\text{C}$

Note 1: Pulse Test with PW=300 usec, 1% Duty Cycle

Note 2: Measured at 1 MHz and Applied VR=4.0 Volts.

Note 3: Reverse Recovery Test Conditions:  $I_F=0.5\text{A}$ ,  $I_R=1.0\text{A}$ ,  $I_{RR}=0.25\text{A}$

RATINGS AND CHARACTERISTIC CURVES (S1AL THRU S1ML)

FIG. 1- MAXIMUM FORWARD CURRENT DERATING CURVE

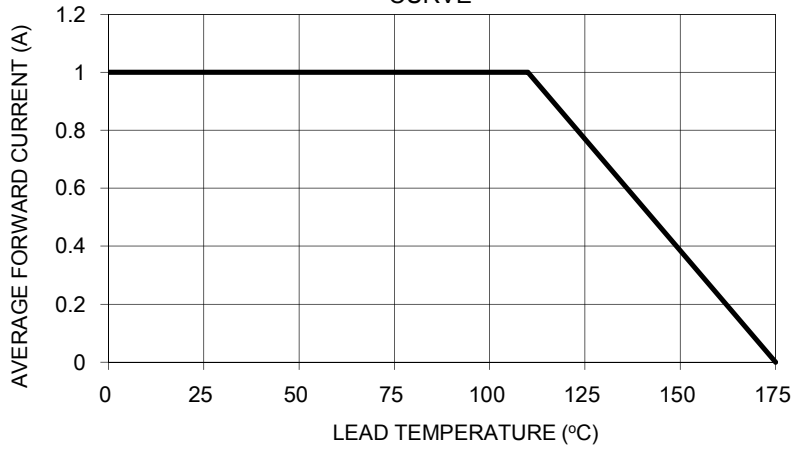

FIG. 2- TYPICAL REVERSE CHARACTERISTICS

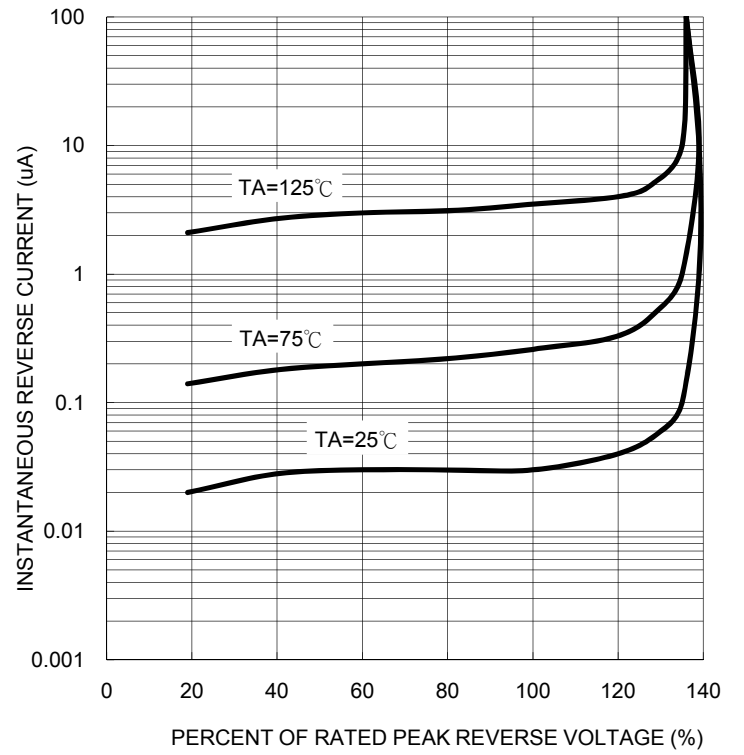

FIG. 3- MAXIMUM NON-REPETITIVE FORWARD SURGE CURRENT

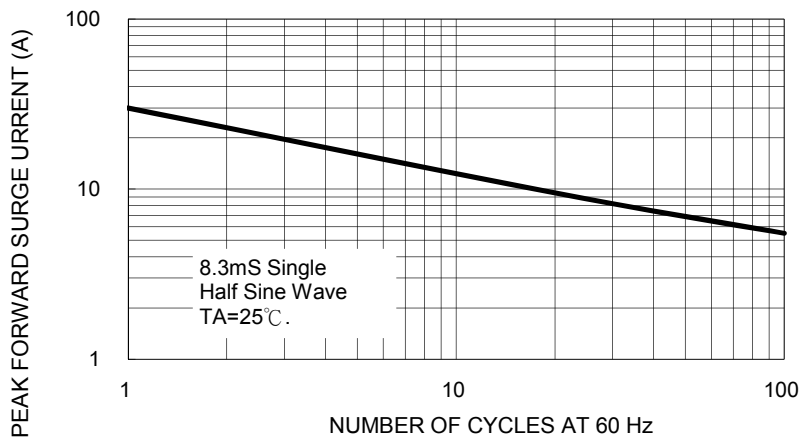

FIG. 5- TYPICAL INSTANTANEOUS FORWARD CHARACTERISTICS

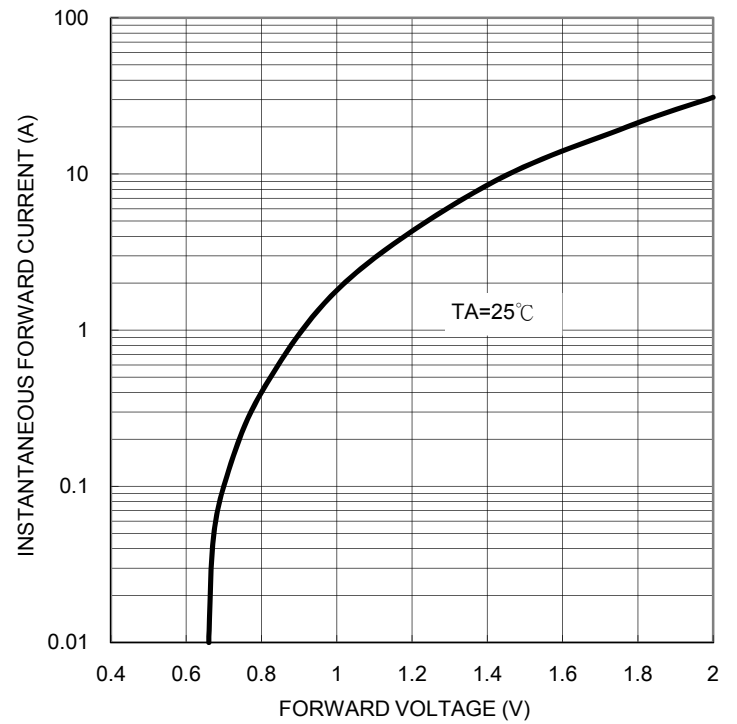
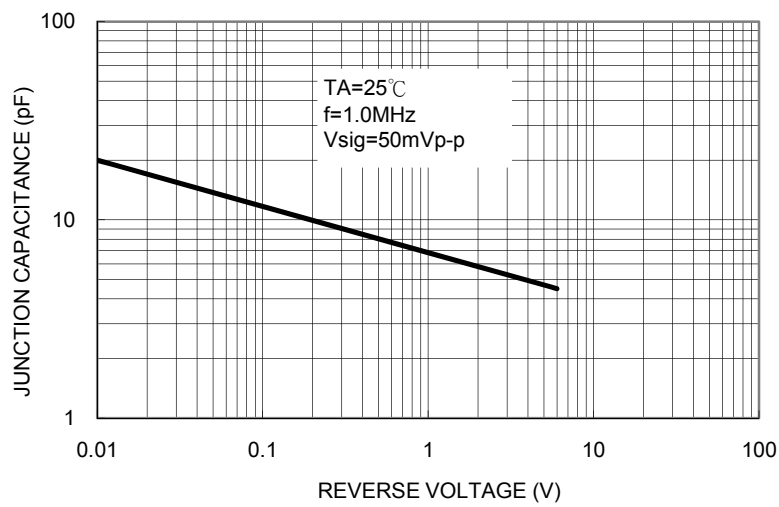

FIG. 4- TYPICAL JUNCTION CAPACITANCE



**Ordering information**

Part No.	Package	Packing	Tape Size	Packing code	Green Compound Packing code
S1XL (Note)	Sub-SMA	1.8K / 7" REEL	8mm	RU	RUG
	Sub-SMA	3K / 7" REEL	8mm	RV	RVG
	Sub-SMA	7.5K / 13" REEL	8mm	RT	RTG
	Sub-SMA	7.5K / 13" REEL	8mm	MT	MTG
	Sub-SMA	10K / 13" REEL	8mm	RQ	RQG
	Sub-SMA	10K / 13" REEL	8mm	MQ	MQG
	Sub-SMA	1.8K / 7" REEL	12mm	R3	R3G
	Sub-SMA	3K / 7" REEL	12mm	RF	RFG
	Sub-SMA	7.5K / 13" REEL	12mm	R2	R2G
	Sub-SMA	7.5K / 13" REEL	12mm	M2	M2G
	Sub-SMA	10K / 13" REEL	12mm	RH	RHG
	Sub-SMA	10K / 13" REEL	12mm	MH	MHG

Note: "x" is Device Code from "A" thru "M".

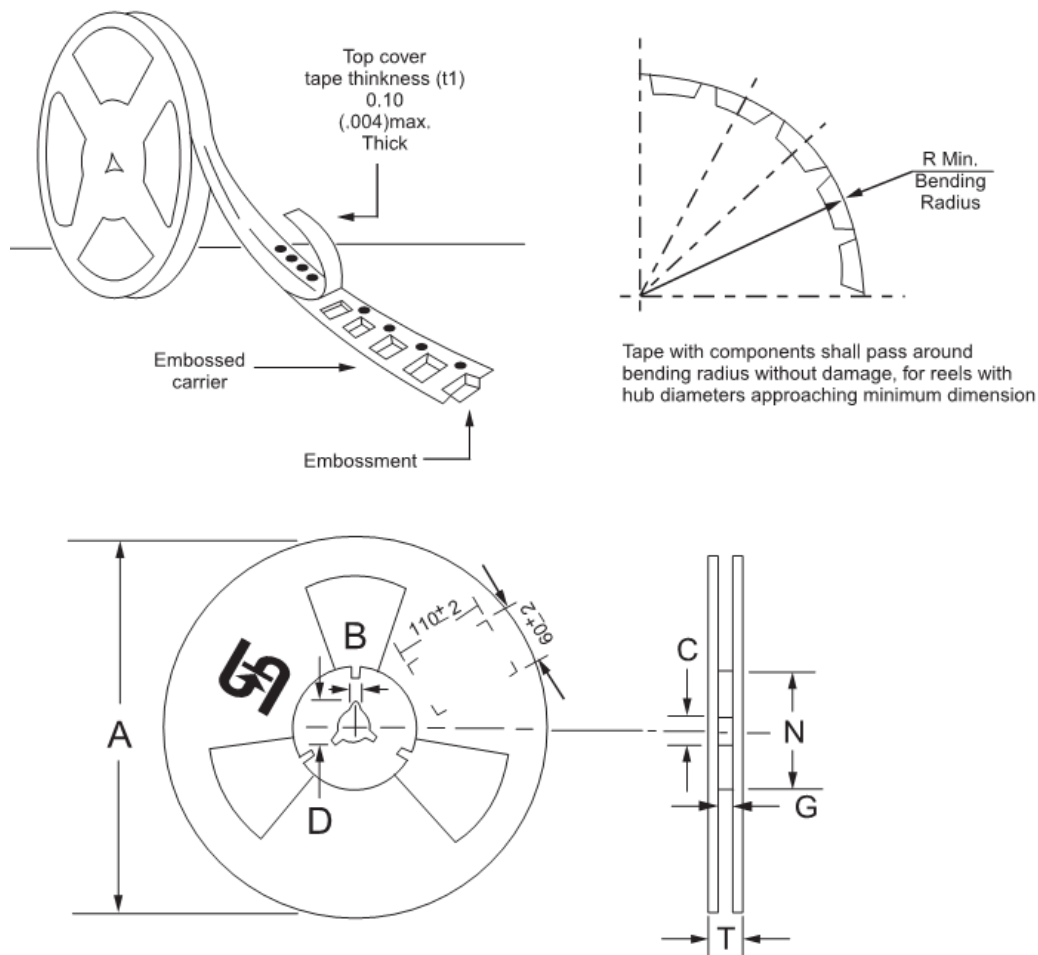
**Tape & Reel specification**

Reel Size	Tape Size	A	B	C	D	N	G	T
		±2.0	±0.4	+0.5;-0.2	min	±1.0	+0.8;-0	max
7"	8mm	178	1.9	13	21	62	8.2	10.6
	12mm						12.2	14.6
Reel Size	Tape Size	A	B	C	D	N	G	T
		max	±0.5	±0.5	min	±0.5	+2.0;-0	max
13"	8mm	330	2	13	20.2	75	8.5	14.5
	12mm						12.4	18.4

Unit (mm)

### Suggested PAD Layout

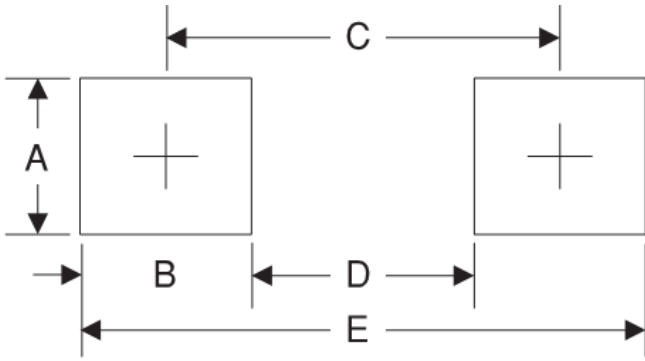

Symbol	Unit(mm)
A	1.4
B	1.2
C	3.1
D	1.9
E	4.3

### Package Outline Dimensions

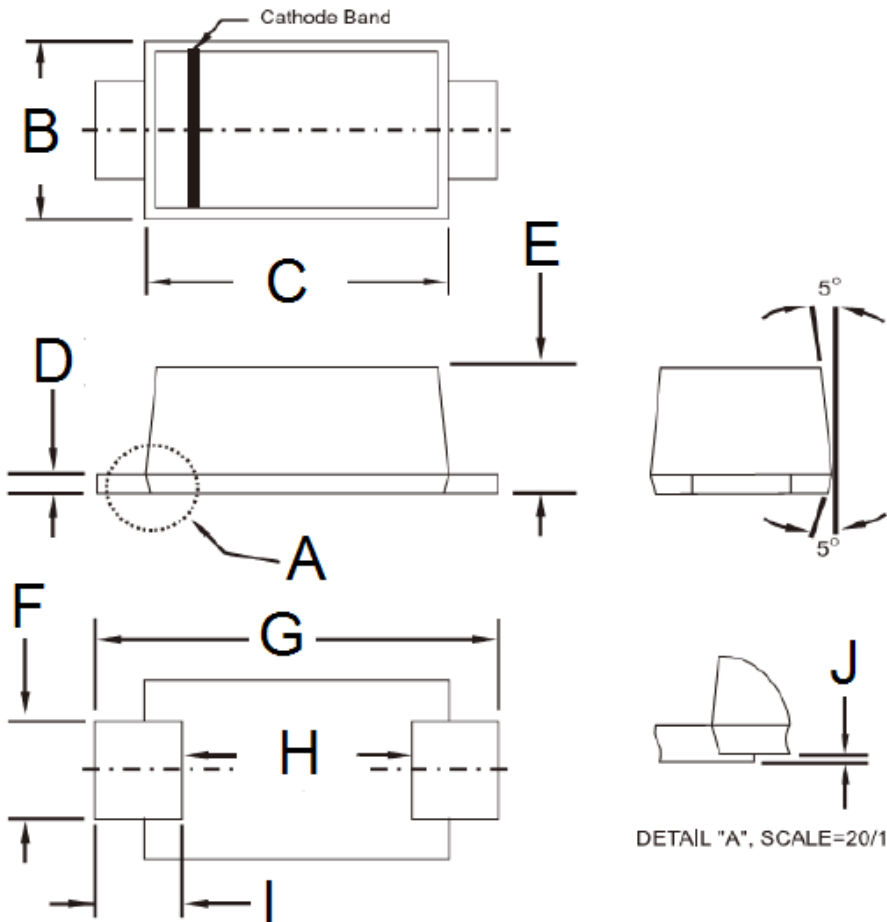

DIM.	Unit(mm)		Unit(inch)	
	Min	Max	Min	Max
B	1.70	1.90	0.067	0.075
C	2.70	2.90	0.106	0.114
D	0.16	0.30	0.006	0.012
E	1.23	1.43	0.048	0.056
F	0.80	1.20	0.031	0.047
G	3.40	3.80	0.134	0.150
H	2.45	2.60	0.096	0.102
I	0.35	0.85	0.014	0.033
J	0.00	0.10	0.000	0.004

### Marking Diagram

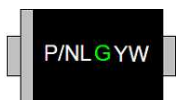

P/NL = Specific Device Code  
 G = Green Compound  
 YW = Date Code