

Features

- ✧ For surface mounted application
- ✧ Glass passivated junction chip
- ✧ Low forward voltage drop
- ✧ High current capability
- ✧ Easy pick and place
- ✧ High surge current capability
- ✧ Plastic material used carries Underwriters Laboratory Classification 94V-0
- ✧ High temperature soldering:
260°C/10 seconds at terminals
- ✧ Green compound with suffix "G" on packing code & prefix "G" on datecode



Mechanical Data

- ✧ Case: Molded plastic
- ✧ Terminal: Pure tin plated, lead free
- ✧ Polarity: Indicated by cathode band
- ✧ Packaging: 12mm tape per EIA STD RS-481
- ✧ Weight: 0.064 grams

Ordering Information (example)

Part No.	Package	Packing	Packing code	Green Compound Packing code
S2AA	SMA	1.8K / 7" REEL	R3	R3G

Maximum Ratings and Electrical Characteristics

Rating at 25 °C ambient temperature unless otherwise specified.

Single phase, half wave, 60 Hz, resistive or inductive load.

For capacitive load, derate current by 20%

Type Number	Symbol	S2 AA	S2 BA	S2 DA	S2 GA	S2 JA	S2 KA	S2 MA	Units
Maximum Recurrent Peak Reverse Voltage	V_{RRM}	50	100	200	400	600	800	1000	V
Maximum RMS Voltage	V_{RMS}	35	70	140	280	420	560	700	V
Maximum DC Blocking Voltage	V_{DC}	50	100	200	400	600	800	1000	V
Maximum Average Forward Rectified Current	$I_{F(AV)}$	1.5							A
Peak Forward Surge Current, 8.3 ms Single Half Sine-wave Superimposed on Rated Load (JEDEC method)	I_{FSM}	50							A
Maximum Instantaneous Forward Voltage (Note 1) @ 1.5A	V_F	1.1							V
Maximum DC Reverse Current at @ $T_A=25\text{ }^\circ\text{C}$ Rated DC Blocking Voltage @ $T_A=125\text{ }^\circ\text{C}$	I_R	5 125							uA uA
Maximum Reverse Recovery Time (Note 2)	T_{rr}	1.5							uS
Typical Junction Capacitance (Note 3)	C_j	30							pF
Typical Thermal Resistance	$R_{\theta JL}$ $R_{\theta JA}$	16 53							$^\circ\text{C/W}$
Operating Temperature Range	T_J	- 55 to + 150							$^\circ\text{C}$
Storage Temperature Range	T_{STG}	- 55 to + 150							$^\circ\text{C}$

Note 1: Pulse Test with PW=300 usec, 1% Duty Cycle

Note 2: Reverse Recovery Test Conditions: $I_F=0.5\text{A}$, $I_R=1.0\text{A}$, $I_{RR}=0.25\text{A}$

Note 3: Measured at 1 MHz and Applied $V_R=4.0\text{ Volts}$

RATINGS AND CHARACTERISTIC CURVES (S2AA THRU S2MA)

FIG. 1- MAXIMUM FORWARD CURRENT DERATING CURVE

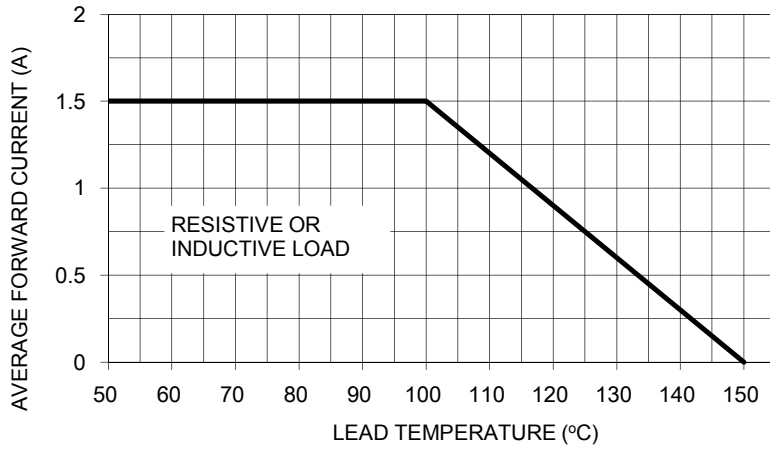

FIG. 2- TYPICAL REVERSE CHARACTERISTICS

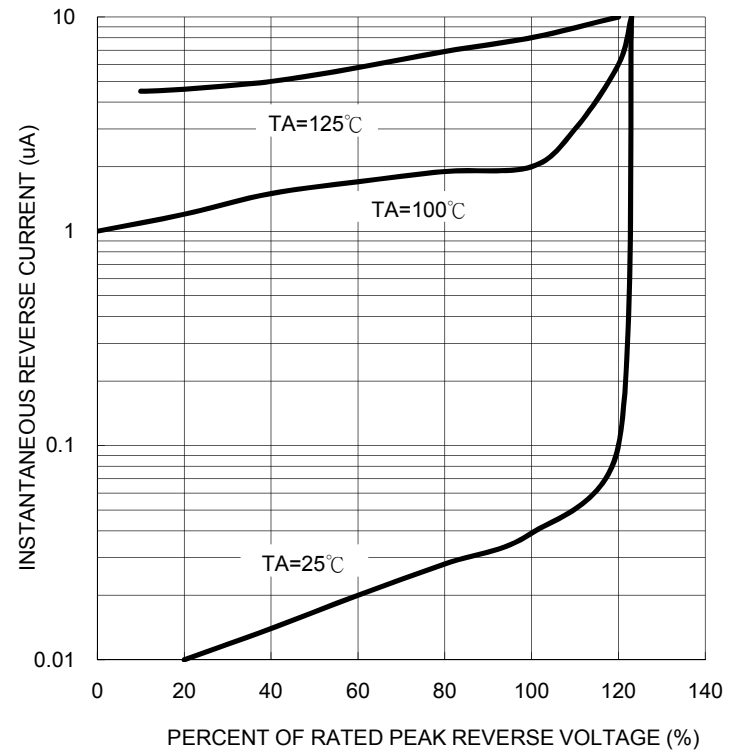

FIG. 3- MAXIMUM NON-REPETITIVE FORWARD SURGE CURRENT

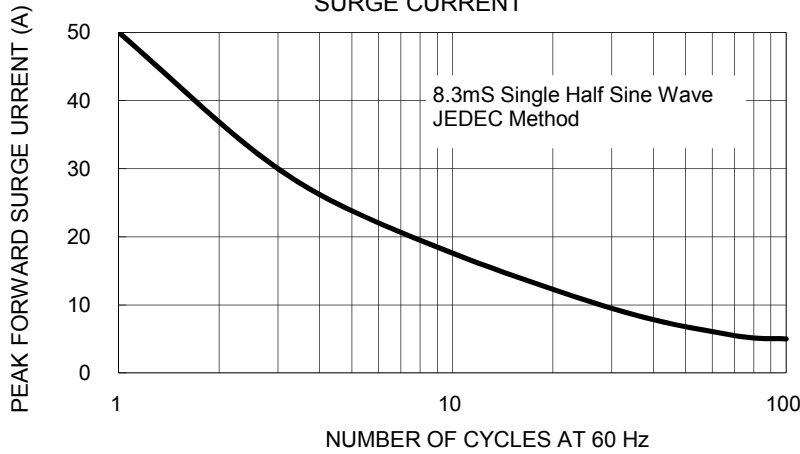

FIG. 5- TYPICAL FORWARD CHARACTERISTICS

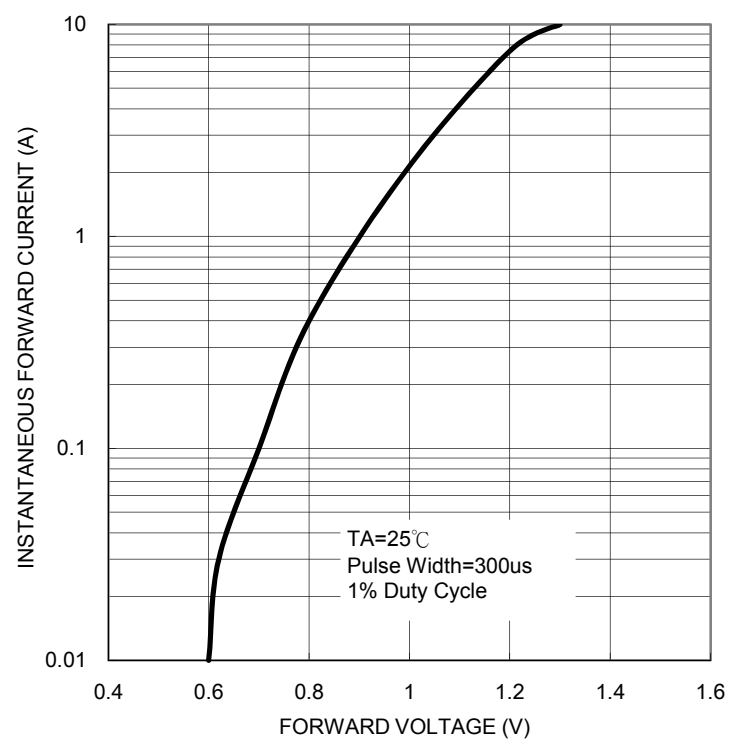

FIG. 4- TYPICAL JUNCTION CAPACITANCE

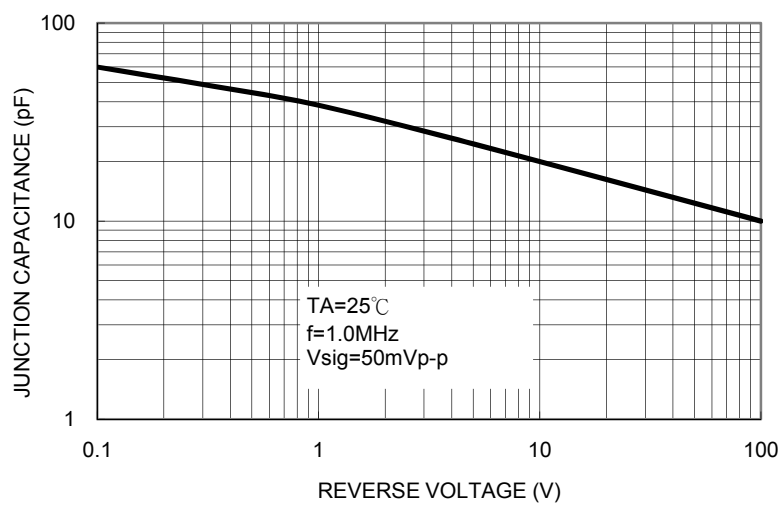
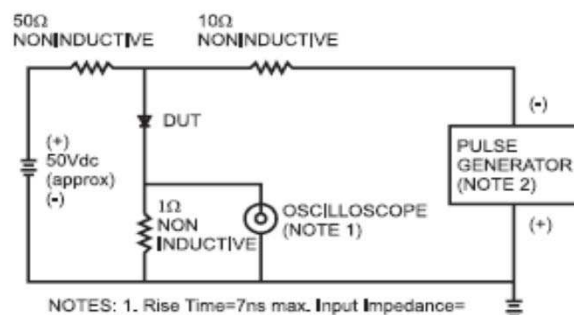
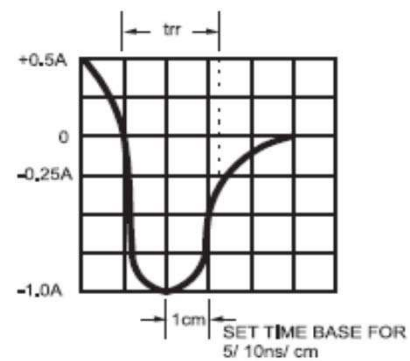

FIG. 6- REVERSE RECOVERY TIME CHARACTERISTIC AND TEST CIRCUIT DIAGRAM



NOTES: 1. Rise Time=7ns max. Input Impedance=1 megohm 22pf
2. Rise Time=10ns max. Source Impedance=50 ohms



Ordering information

Part No.	Package	Packing	Packing code	Green Compound Packing code
S2XA (Note)	SMA	1.8K / 7" REEL	R3	R3G
	SMA	7.5K / 13" REEL	R2	R2G
	Folded SMA	1.8K / 7" REEL	F3	F3G
	Folded SMA	7.5K / 13" REEL	F2	F2G
	C SMA	1.8K / 7" REEL	E3	E3G
	C SMA	7.5K / 13" REEL	E2	E2G

Note: "x" is Device Code from "A" thru "M".

Tape & Reel specification

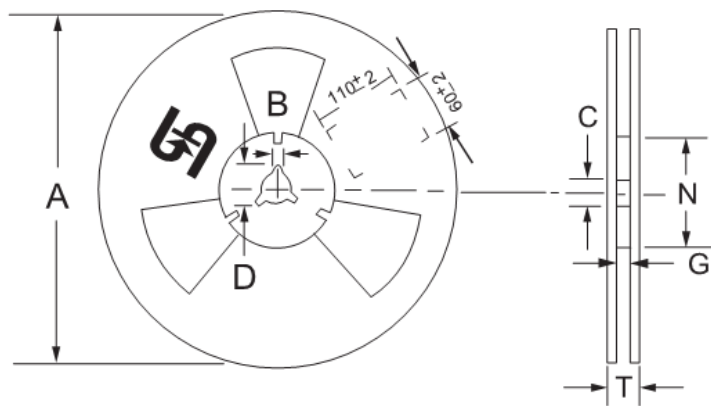
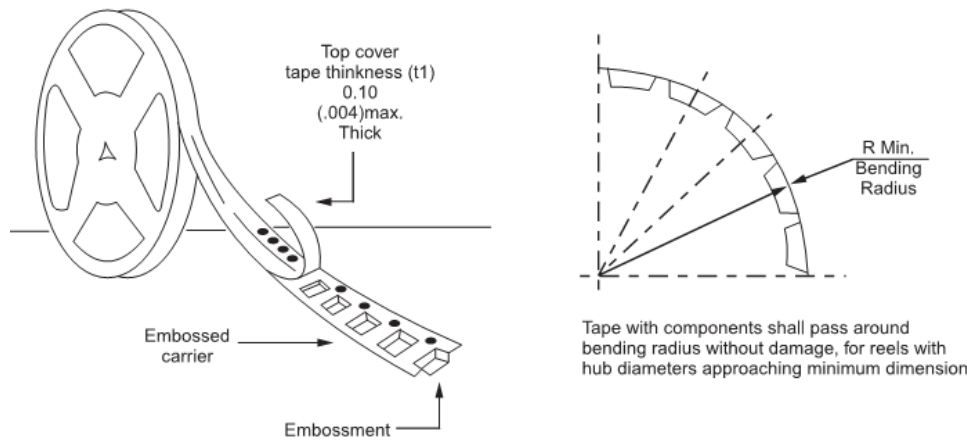

Reel Size	Tape Size	A	B	C	D	N	G	T
		±2.0	±0.4	+0.5;-0.2	min	±1.0	+0.8;-0	max
7"	12mm	178	1.9	13	21	62	12.2	14.6
Reel Size	Tape Size	A	B	C	D	N	G	T
		max	±0.5	±0.5	min	±0.5	+2.0;-0	max
13"	12mm	330	2	13	20.2	75	12.4	18.4

Unit (mm)

Suggested PAD Layout

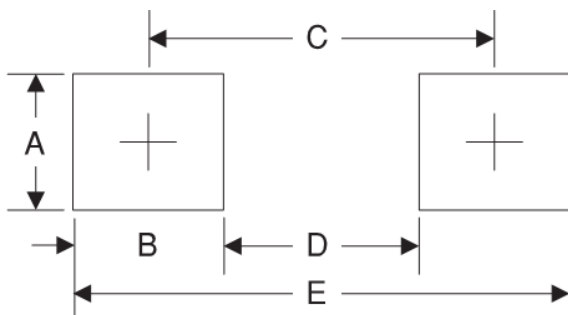

Symbol	Unit(mm)
A	1.78
B	1.51
C	3.92
D	2.41
E	4.43

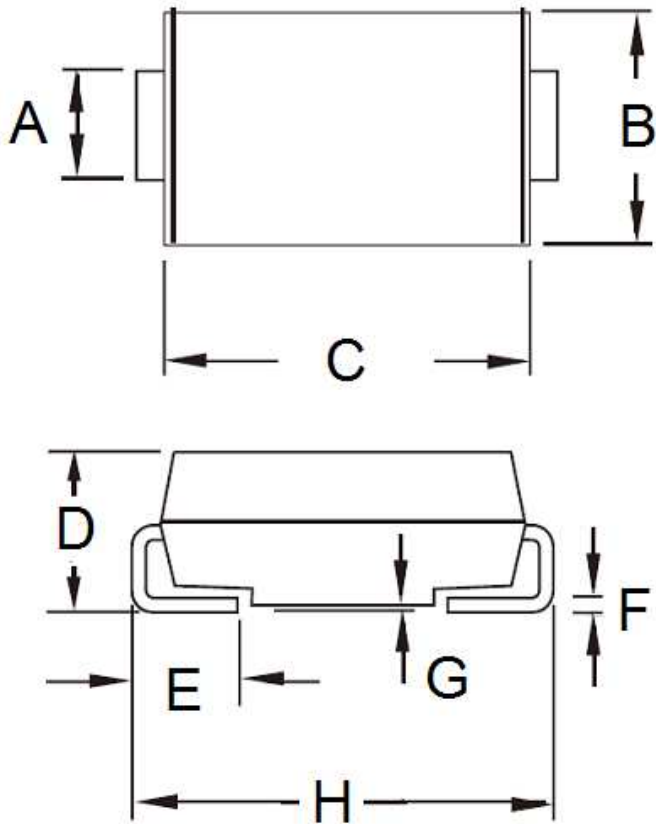
Package Outline Dimensions

DIM.	Unit(mm)		Unit(inch)	
	Min	Max	Min	Max
A	1.27	1.58	0.050	0.062
B	2.29	2.83	0.090	0.111
C	4.06	4.60	0.160	0.181
D	1.99	2.50	0.078	0.098
E	0.90	1.41	0.035	0.056
F	0.15	0.31	0.006	0.012
G	0.10	0.20	0.004	0.008
H	4.95	5.33	0.195	0.210

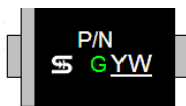
Marking Diagram

P/N = Specific Device Code
 G = Green Compound
 YW = Date Code