

### Features

- ✧ For surface mounted application
- ✧ Glass passivated chip junction
- ✧ Low forward voltage drop
- ✧ High current capability
- ✧ Easy pick and place
- ✧ High surge current capability
- ✧ Plastic material used carries Underwriters Laboratory Classification 94V-0
- ✧ High temperature soldering: 260°C/10 seconds at terminals
- ✧ Green compound with suffix "G" on packing code & prefix "G" on datecode



### Mechanical Data

- ✧ Case: Molded plastic
- ✧ Terminals: Pure tin plated, lead free
- ✧ Polarity: Indicated by cathode band
- ✧ Packing: 12mm tape per EIA STD RS-481
- ✧ Weight: 0.093 grams

### Ordering Information (example)

Part No.	Package	Packing	Packing code	Green Compound Packing code
S3AB	SMB	850 / 7" REEL	R5	R5G

### Maximum Ratings and Electrical Characteristics

Rating at 25 °C ambient temperature unless otherwise specified.

Single phase, half wave, 60 Hz, resistive or inductive load.

For capacitive load, derate current by 20%

Type Number	Symbol	S3 AB	S3 BB	S3 DB	S3 GB	S3 JB	S3 KB	S3 MB	Unit
Maximum Repetitive Peak Reverse Voltage	$V_{RRM}$	50	100	200	400	600	800	1000	V
Maximum RMS Voltage	$V_{RMS}$	35	70	140	280	420	560	700	V
Maximum DC Blocking Voltage	$V_{DC}$	50	100	200	400	600	800	1000	V
Maximum Average Forward Rectified Current	$I_{F(AV)}$	3							A
Peak Forward Surge Current, 8.3 ms Single Half Sine-wave Superimposed on Rated Load (JEDEC method)	$I_{FSM}$	80							A
Maximum Instantaneous Forward Voltage (Note 1) @ 3 A	$V_F$	1.15							V
Maximum Reverse Current @ Rated VR $T_A=25\text{ }^\circ\text{C}$ $T_A=125\text{ }^\circ\text{C}$	$I_R$	10 250							uA
Maximum Reverse Recovery Time (Note 2)	$T_{rr}$	1.5							uS
Typical Junction Capacitance (Note 3)	$C_j$	40							pF
Typical Thermal Resistance	$R_{\theta JL}$	10							$^\circ\text{C/W}$
Operating Temperature Range	$T_J$	- 55 to + 150							$^\circ\text{C}$
Storage Temperature Range	$T_{STG}$	- 55 to + 150							$^\circ\text{C}$

Note 1: Pulse Test with PW=300 usec, 1% Duty Cycle

Note 2: Reverse Recovery Test Conditions:  $I_F=0.5A$ ,  $I_R=1.0A$ ,  $I_{RR}=0.25A$

Note 3: Measured at 1 MHz and Applied Reverse Voltage of 4.0V D.C.

RATINGS AND CHARACTERISTIC CURVES (S3AB THRU S3MB)

FIG.1 FORWARD CURRENT DERATING CURVE

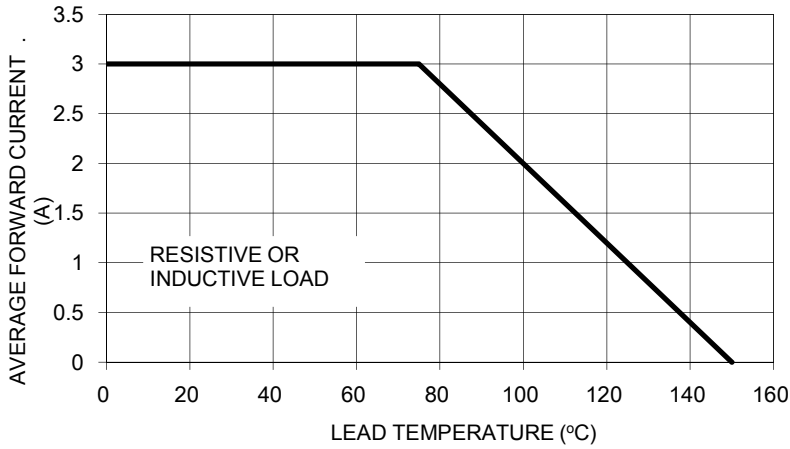

FIG. 2 TYPICAL REVERSE CHARACTERISTICS

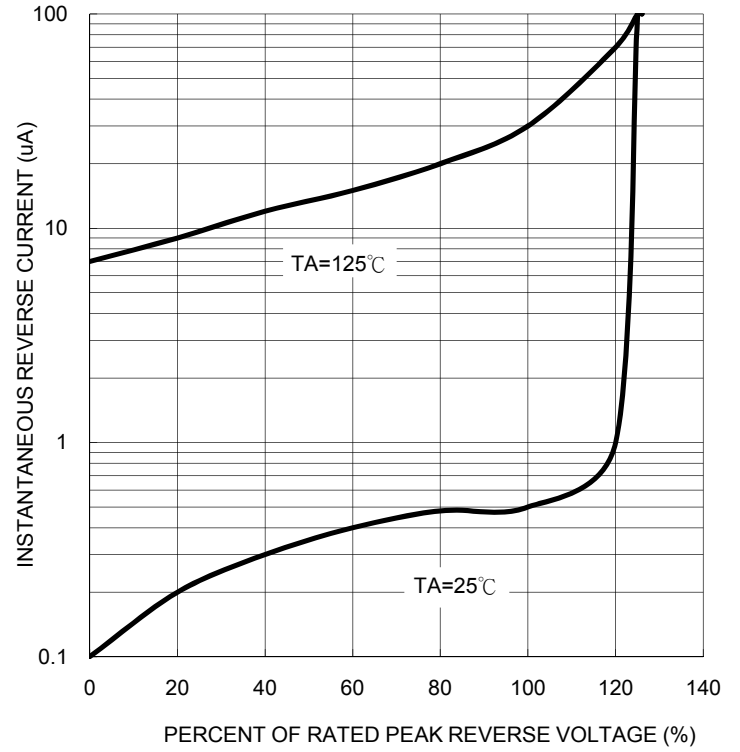

FIG. 3 MAXIMUM NON-REPETITIVE FORWARD SURGE CURRENT

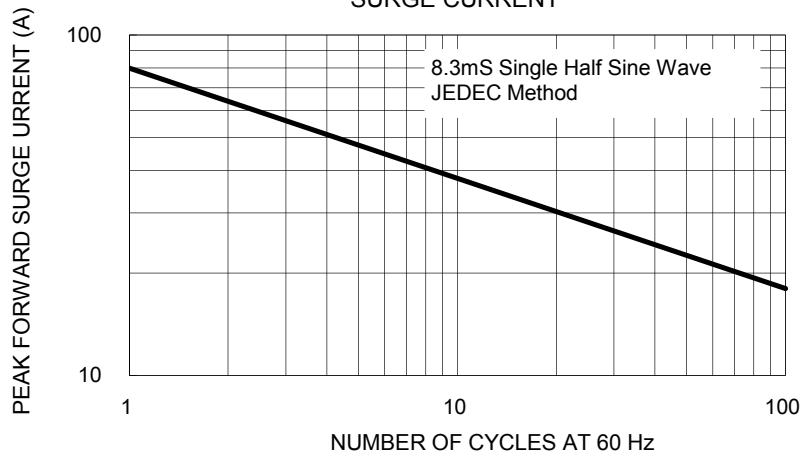

FIG. 5 TYPICAL FORWARD CHARACTERISTICS

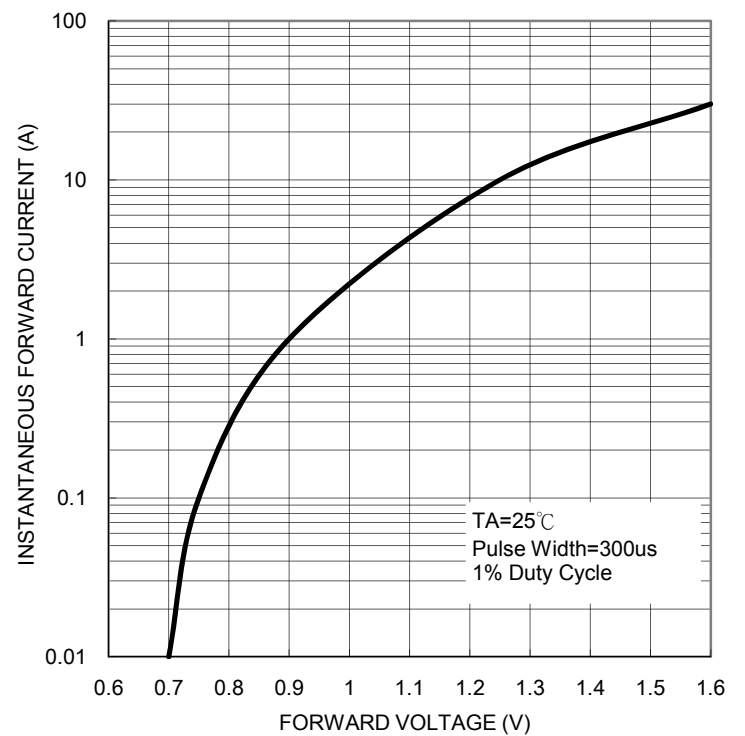

FIG. 4 TYPICAL JUNCTION CAPACITANCE

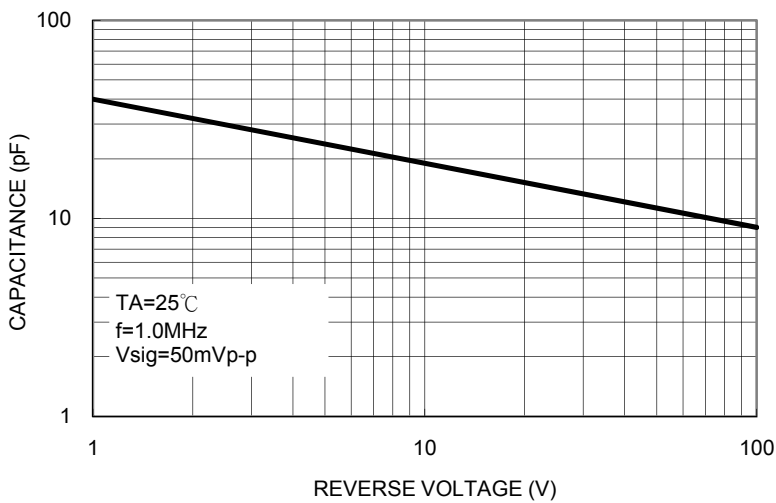
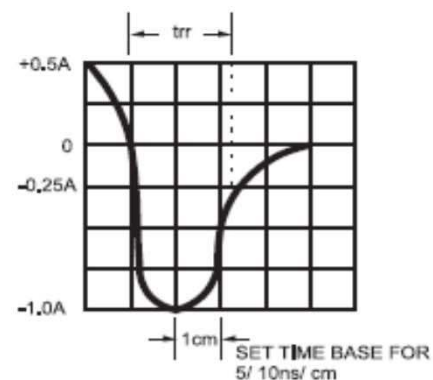
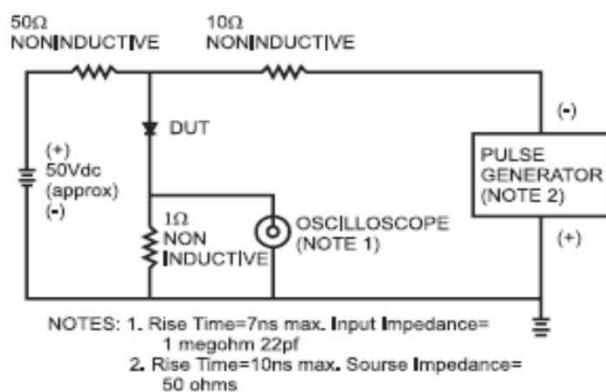

FIG.6- REVERSE RECOVERY TIME CHARACTERISTIC AND TEST CIRCUIT DIAGRAM



### Ordering information

Part No.	Package	Packing	Packing code	Green Compound Packing code
S3XB (Note)	SMB	850 / 7" REEL	R5	R5G
	SMB	3K / 13" REEL	R4	R4G

Note: "x" is Device Code from "A" thru "M".

### Tape & Reel specification

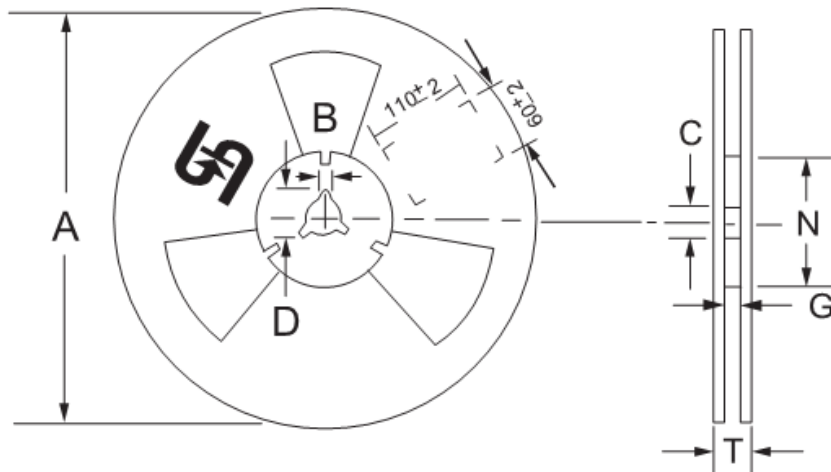
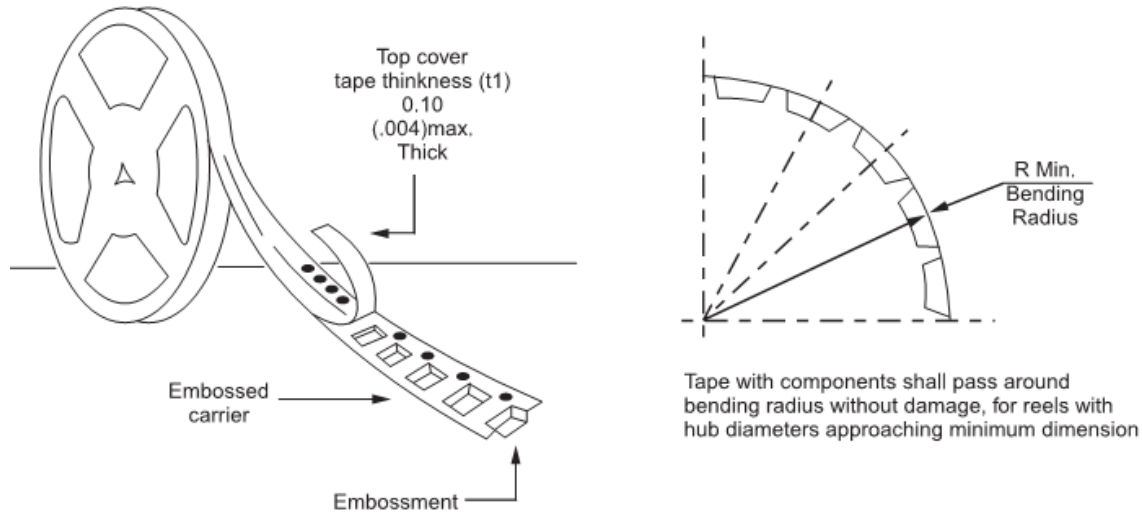

Reel Size	Tape Size	A	B	C	D	N	G	T
		±2.0	±0.4	+0.5;-0.2	min	±1.0	+0.8;-0	max
7"	12mm	178	1.9	13	21	62	12.2	14.6
Reel Size	Tape Size	A	B	C	D	N	G	T
		max	±0.5	±0.5	min	±0.5	+2.0;-0	max
13"	12mm	330	2	13	20.2	75	12.4	18.4

Unit (mm)

### Suggested PAD Layout

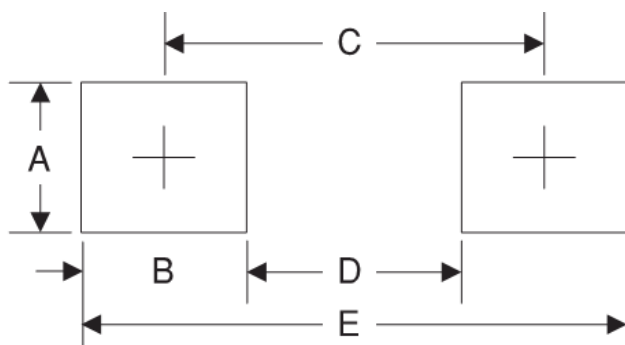

Symbol	Unit(mm)
A	2.3
B	2.5
C	4.3
D	1.8
E	6.7

**Dimensions**

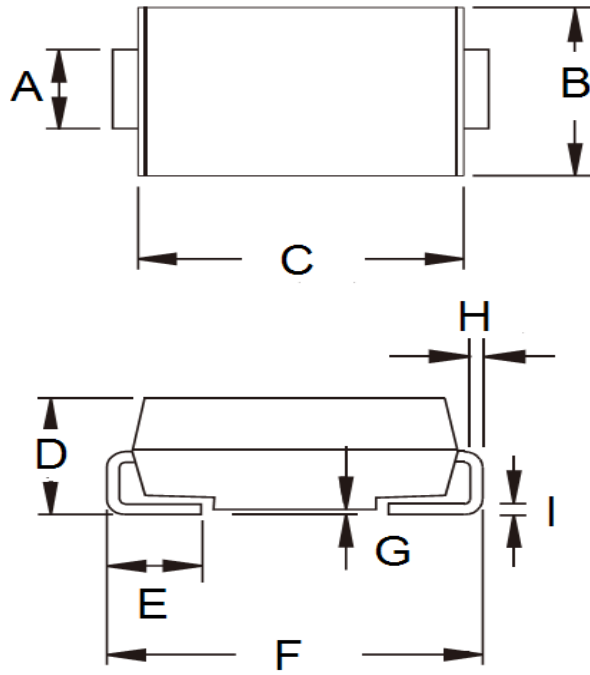

DIM.	Unit(mm)		Unit(inch)	
	Min	Max	Min	Max
A	1.95	2.10	0.077	0.083
B	3.48	3.73	0.137	0.147
C	4.25	4.75	0.167	0.187
D	1.99	2.61	0.078	0.103
E	0.90	1.41	0.035	0.056
F	5.10	5.30	0.201	0.209
G	0.10	0.20	0.004	0.008
H	0.15	0.31	0.006	0.012
I	0.15	0.31	0.006	0.012

**Marking Diagram**

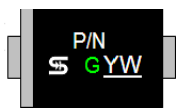

- P/N = Specific Device Code
- G = Green Compound
- YW = Date Code