

### Small Signal Diode



#### Features

- ✧ Fast switching device ( $T_{rr} < 4.0nS$ )
- ✧ Surface device type mounting
- ✧ Moisture sensitivity level 1
- ✧ Matte Tin (Sn) lead finish with Nickel (Ni) underplate
- ✧ Pb free version and RoHS compliant
- ✧ Green compound (Halogen free) with suffix "G" on packing code and prefix "G" on date code

#### Mechanical Data

- ✧ Case : Flat lead SOD-123 small outline plastic package
- ✧ Terminal: Matte tin plated, lead free., solderable per MIL-STD-202, Method 208 guaranteed
- ✧ High temperature soldering guaranteed: 260°C/10s
- ✧ Polarity : Indicated by cathode band
- ✧ Weight : 8.85±0.5 mg
- ✧ Marking Code : D1, D2, D3

#### Ordering Information

Package	Part No.	Packing	Marking
SOD-123F	1N4148W RH	3K / 7" Reel	D1
SOD-123F	1N4448W RH	3K / 7" Reel	D2
SOD-123F	1N9148B RH	3K / 7" Reel	D3
SOD-123F	1N4148W RHG	3K / 7" Reel	D1
SOD-123F	1N4448W RHG	3K / 7" Reel	D2
SOD-123F	1N9148B RHG	3K / 7" Reel	D3

#### Maximum Ratings and Electrical Characteristics

Rating at 25°C ambient temperature unless otherwise specified.

#### Maximum Ratings

Type Number	Symbol	Value	Units
Power Dissipation	$P_D$	400	mW
Non-Repetitive Peak Reverse Voltage	$V_{RSM}$	100	V
Repetitive Peak Reverse Voltage	$V_{RRM}$	100	V
Repetitive Peak Forward Current	$I_{FRM}$	300	mA
Mean Forward Current	$I_O$	150	mA
Thermal Resistance (Junction to Ambient) (Note 1)	$R_{\theta JA}$	450	°C/W
Junction and Storage Temperature Range	$T_J, T_{STG}$	-65 to + 150	°C

Notes: 1. Test Condition : 8.3ms Single half Sine-Wave Superimposed on Rated Load (JEDEC Method)

#### SOD-123

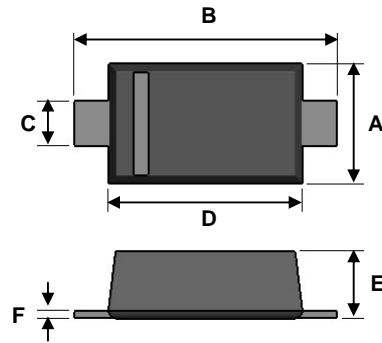

Dimensions	Unit (mm)		Unit (inch)	
	Min	Max	Min	Max
A	1.5	1.7	0.059	0.067
B	3.3	3.7	0.130	0.146
C	0.5	0.7	0.020	0.028
D	2.5	2.7	0.098	0.106
E	0.8	1.15	0.031	0.039
F	0.05	0.2	0.002	0.008

#### Pin Configuration



#### Suggested PAD Layout

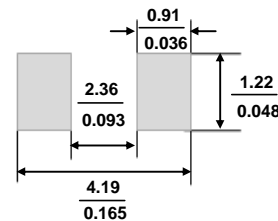

**Small Signal Diode**

**Electrical Characteristics**

Type Number		Symbol	Min	Max	Units
Reverse Breakdown Voltage	$I_R = 100\mu A$	$V_{(BR)}$	100	-	V
	$I_R = 5\mu A$		75	-	
Forward Voltage	1N4448W, 1N914BW	$V_F$	0.62	0.72	V
	1N4148W		-	1.0	
	1N4448W, 1N914BW		-	1.0	
Reverse Leakage Current	$V_R = 20V$	$I_R$	-	25	nA
	$V_R = 75V$		-	5.0	$\mu A$
Junction Capacitance	$V_R = 0, f = 1.0MHz$	$C_J$	-	4.0	pF
Reverse Recovery Time (Note 2)		$T_{rr}$	-	4.0	ns

Notes: 2. Reverse Recovery Test Conditions:  $I_F = 10mA$ ,  $I_R = 60mA$ ,  $R_L = 100\Omega$ ,  $I_{RR} = 1mA$

**Tape & Reel specification**

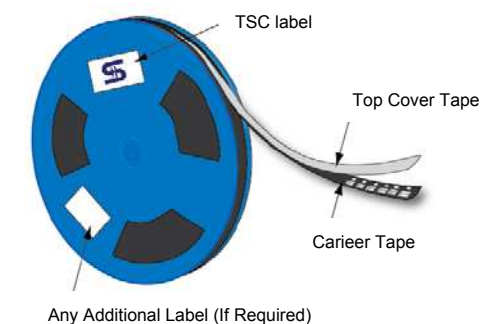

Item	Symbol	Dimension
Carrier width	A	1.85 ± 0.10
Carrier length	B	3.94 ± 0.10
Carrier depth	C	1.50 ± 0.10
Sprocket hole	d	1.5 ± 0.1
Reel outside diameter	D	178 ± 1
Reel inner diameter	D1	55 Min
Feed hole width	D2	13.0 ± 0.20
Sprocket hole position	E	1.75 ± 0.10
Punch hole position	F	3.50 ± 0.05
Sprocket hole pitch	P0	4.00 ± 0.10
Embossment center	P1	2.00 ± 0.05
Overall tape thickness	T	0.23 ± 0.05
Tape width	W	8.00 ± 0.20
Reel width	W1	14.4 Max

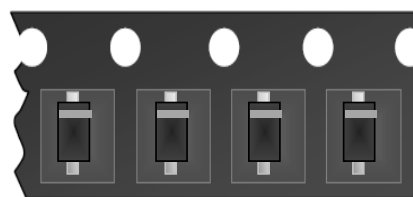
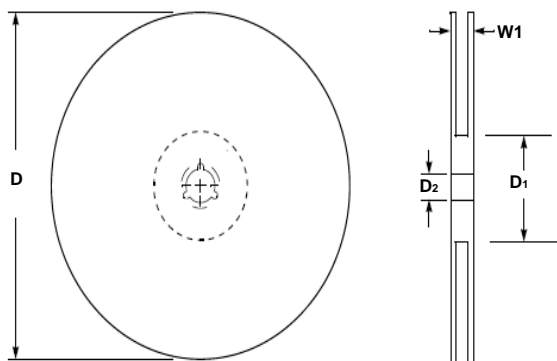
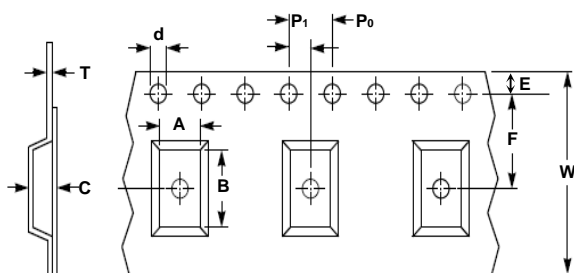

**Small Signal Diode**

**Rating and Sharacteristic Curves**

**FIG 1 Typical Forward Characteristics**

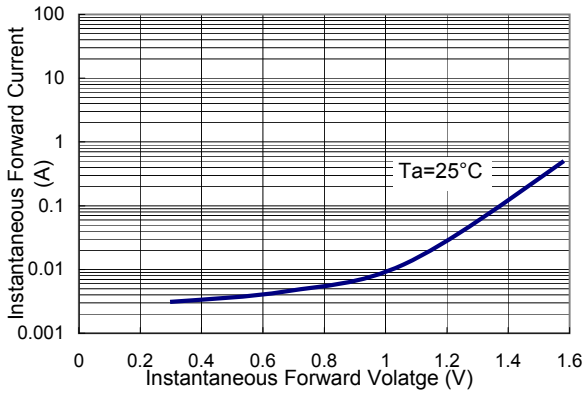

**FIG 2 Reverse Current vs Reverse Voltage**

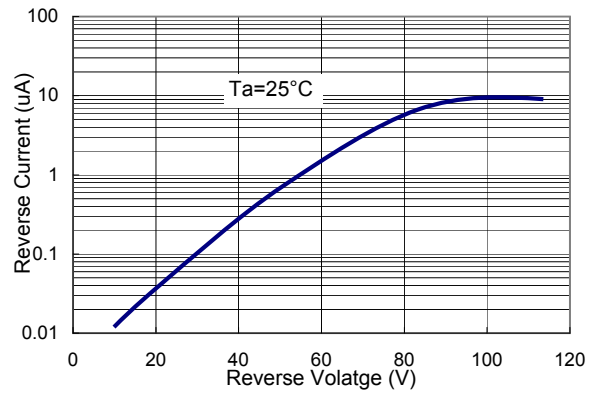

**FIG 3 Admissible Power Dissipation Curve**

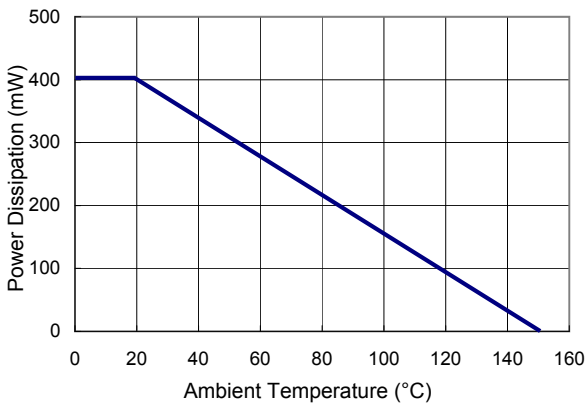

**FIG 4 Typical Junction Capacitance**

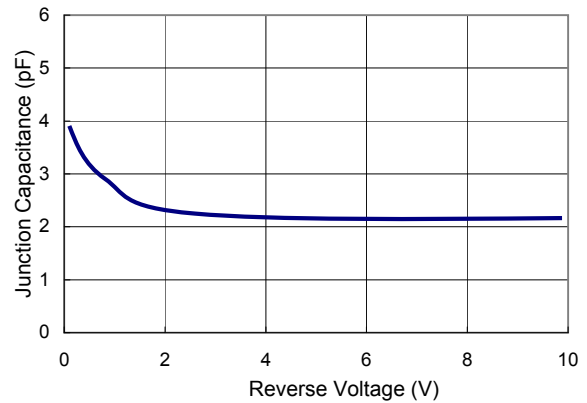

**FIG 5 Forward Resistance vs. Forward Current**

