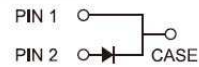
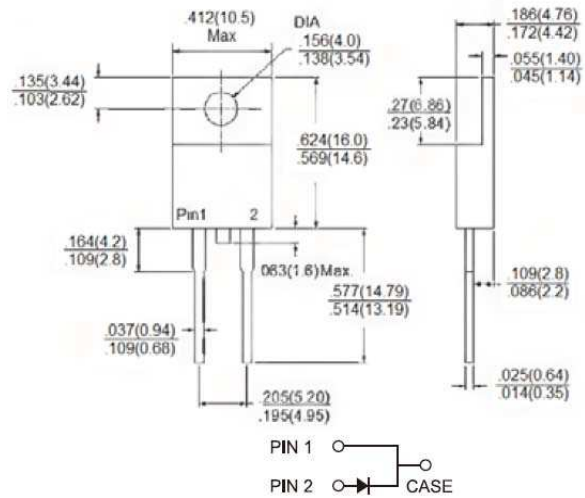

**TO-220AC**

**Features**

- ✧ High efficiency, low VF
- ✧ High current capability
- ✧ High reliability
- ✧ High surge current capability
- ✧ Low power loss
- ✧ For use in low voltage, high frequency inverter, Free wheeling, and polarity protection application
- ✧ Green compound with suffix "G" on packing code & prefix "G" on datecode

**Mechanical Data**

- ✧ Case: TO-220AC Molded plastic
- ✧ Epoxy: UL 94V-0 rate flame retardant
- ✧ Terminals: Pure tin plated, lead free, solderable per MIL-STD-202, Method 208 guaranteed
- ✧ Polarity: As marked
- ✧ High temperature soldering: 260°C/10 seconds/.16"(.406mm) from case
- ✧ Weight: 1.9 grams

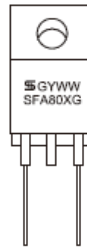
**Dimensions in inches and (millimeters)**

**Marking Diagram**

- SFA160XG = Specific Device Code
- G = Green Compound
- Y = Year
- WW = Work Week

**Maximum Ratings and Electrical Characteristics**

Rating at 25 °C ambient temperature unless otherwise specified.

Single phase, half wave, 60 Hz, resistive or inductive load.

For capacitive load, derate current by 20%

Type Number	Symbol	SFA 801G	SFA 802G	SFA 803G	SFA 804G	SFA 805G	SFA 806G	SFA 807G	SFA 808G	Unit
Maximum Repetitive Peak Reverse Voltage	$V_{RRM}$	50	100	150	200	300	400	500	600	V
Maximum RMS Voltage	$V_{RMS}$	35	70	105	140	210	280	350	420	V
Maximum DC Blocking Voltage	$V_{DC}$	50	100	150	200	300	400	500	600	V
Maximum Average Forward Rectified Current	$I_{F(AV)}$	8								A
Peak Forward Surge Current, 8.3 ms Single Half Sine-wave Superimposed on Rated Load (JEDEC method)	$I_{FSM}$	125								A
Maximum Instantaneous Forward Voltage (Note 1) @ 8 A	$V_F$	0.975			1.3		1.7			V
Maximum Reverse Current @ Rated VR $T_A=25\text{ }^\circ\text{C}$ $T_A=100\text{ }^\circ\text{C}$	$I_R$	10				400				uA
Maximum Reverse Recovery Time (Note 2)	$T_{rr}$	35								nS
Typical Junction Capacitance (Note 3)	$C_j$	100				60				pF
Typical Thermal Resistance	$R_{\theta JC}$	4								°C/W
Operating Temperature Range	$T_J$	- 65 to + 150								°C
Storage Temperature Range	$T_{STG}$	- 65 to + 150								°C

Note 1: Pulse Test with PW=300 usec, 1% Duty Cycle

 Note 2: Reverse Recovery Test Conditions:  $I_F=0.5A$ ,  $I_R=1.0A$ ,  $I_{RR}=0.25A$ 

Note 3: Measured at 1 MHz and Applied Reverse Voltage of 4.0V D.C.

## RATINGS AND CHARACTERISTIC CURVES (SFA801G THRU SFA808G)

FIG.1 FORWARD CURRENT DERATING CURVE

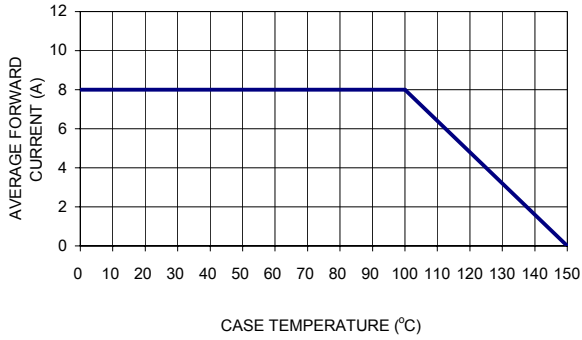

FIG. 2 TYPICAL REVERSE CHARACTERISTICS

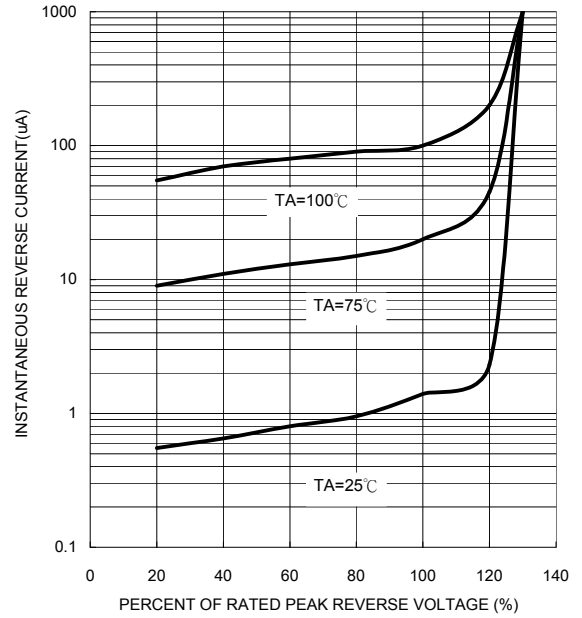

FIG. 3 MAXIMUM NON-REPETITIVE FORWARD SURGE CURRENT

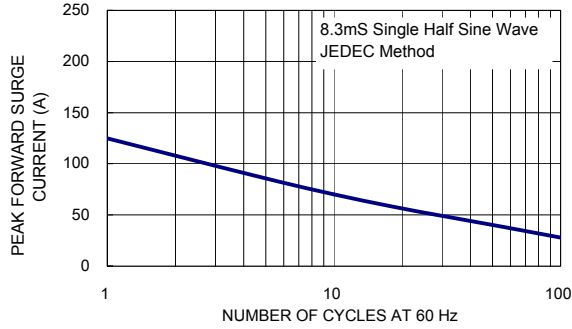

FIG. 5 TYPICAL FORWARD CHARACTERISTICS

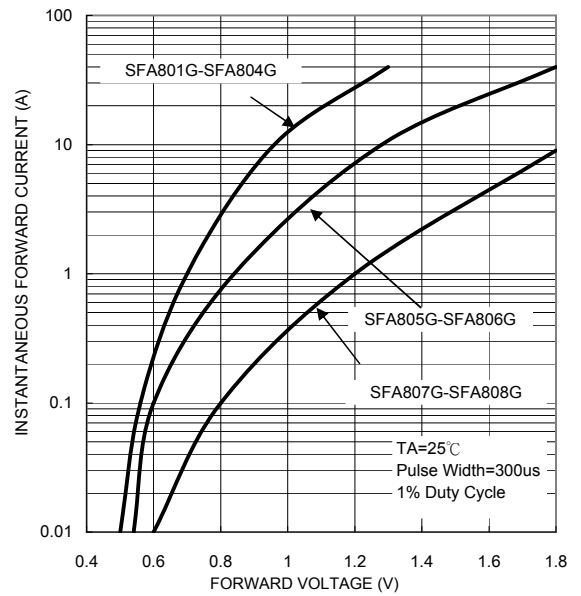

FIG. 4 TYPICAL JUNCTION CAPACITANCE

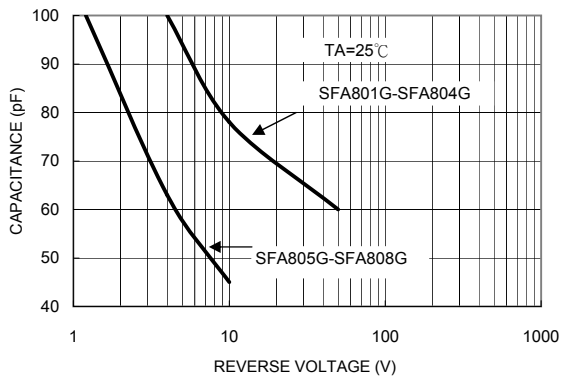

FIG.6- REVERSE RECOVERY TIME CHARACTERISTIC AND TEST CIRCUIT DIAGRAM

