

D²PAK



Features

- ✧ Low forward voltage drop
- ✧ High current capability
- ✧ High reliability
- ✧ High surge current capability
- ✧ Green compound with suffix "G" on packing code & prefix "G" on datecode
- ✧ Qualified as per AEC-Q101

Mechanical Data

- ✧ Case: D²PAK Molded plastic
- ✧ Epoxy: UL 94V-0 rate flame retardant
- ✧ Terminals: Pure tin plated, lead free, solderable per MIL-STD-202, Method 208 guaranteed
- ✧ Polarity: As marked
- ✧ High temperature soldering: 260°C / 10 seconds / .16" (4.06mm) from case
- ✧ Weight: 1.70 grams

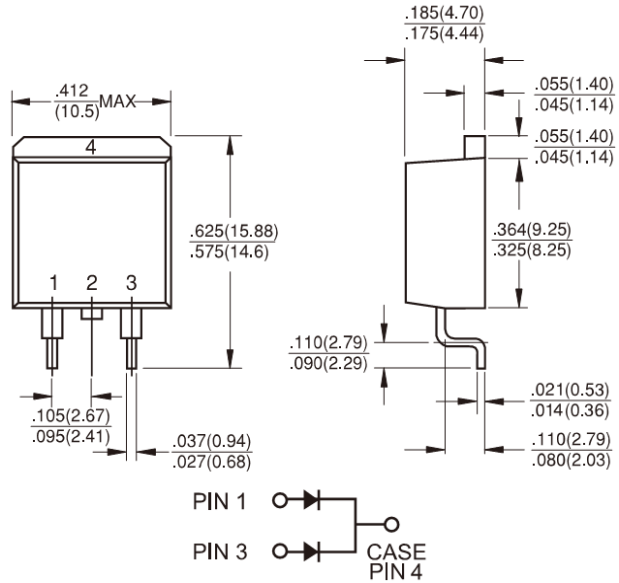

Dimensions in inches and (millimeters)

Marking Diagram



- SFS100XG = Specific Device Code
- G = Green Compound
- Y = Year
- WW = Work Week

Maximum Ratings and Electrical Characteristics

Rating at 25 °C ambient temperature unless otherwise specified.

Single phase, half wave, 60 Hz, resistive or inductive load.

For capacitive load, derate current by 20%

Type Number	Symbol	SFS 1001G	SFS 1002G	SFS 1003G	SFS 1004G	SFS 1005G	SFS 1006G	SFS 1007G	SFS 1008G	Unit
Maximum Repetitive Peak Reverse Voltage	V_{RRM}	50	100	150	200	300	400	500	600	V
Maximum RMS Voltage	V_{RMS}	35	70	105	140	210	280	350	420	V
Maximum DC Blocking Voltage	V_{DC}	50	100	150	200	300	400	500	600	V
Maximum Average Forward Rectified Current @ $T_C=100^\circ\text{C}$	$I_{F(AV)}$	10.0								A
Peak Forward Surge Current, 8.3 ms Single Half Sine-wave Superimposed on Rated Load (JEDEC method)	I_{FSM}	125								A
Maximum Instantaneous Forward Voltage @ 5.0A	V_F	0.975			1.3		1.7			V
Maximum DC Reverse Current @ Rated DC Blocking Voltage	I_R	$T_A=25^\circ\text{C}$		1						uA
		$T_A=125^\circ\text{C}$		200						
Maximum Reverse Recovery Time (Note 1)	T_{rr}	35								nS
Typical Junction Capacitance (Note 2)	C_j	70			50					pF
Typical Thermal Resistance	$R_{\theta JC}$	2								$^\circ\text{C/W}$
Operating Temperature Range	T_J	- 65 to + 150								$^\circ\text{C}$
Storage Temperature Range	T_{STG}	- 65 to + 150								$^\circ\text{C}$

Note 1: Reverse Recovery Test Conditions: $I_F=0.5\text{A}$, $I_R=1.0\text{A}$, $I_{RR}=0.25\text{A}$

Note 2: Measured at 1 MHz and Applied Reverse Voltage of 4.0V D.C.

RATINGS AND CHARACTERISTIC CURVES (SFS1001G THRU SFS1008G)

FIG.1 FORWARD CURRENT DERATING CURVE

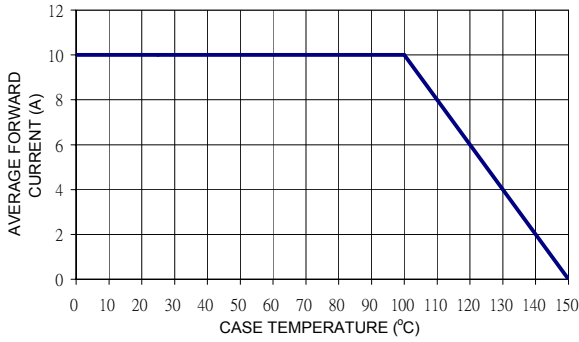

FIG. 2 TYPICAL REVERSE CHARACTERISTICS

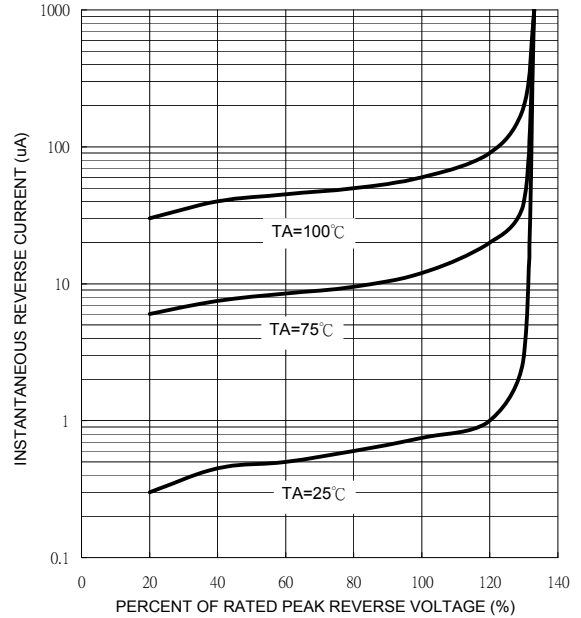

FIG. 3 MAXIMUM NON-REPETITIVE FORWARD SURGE CURRENT

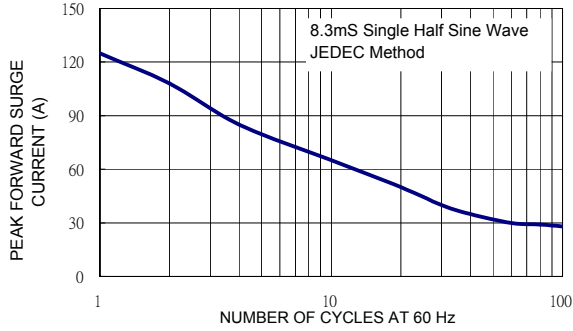

FIG. 5 TYPICAL FORWARD CHARACTERISTICS

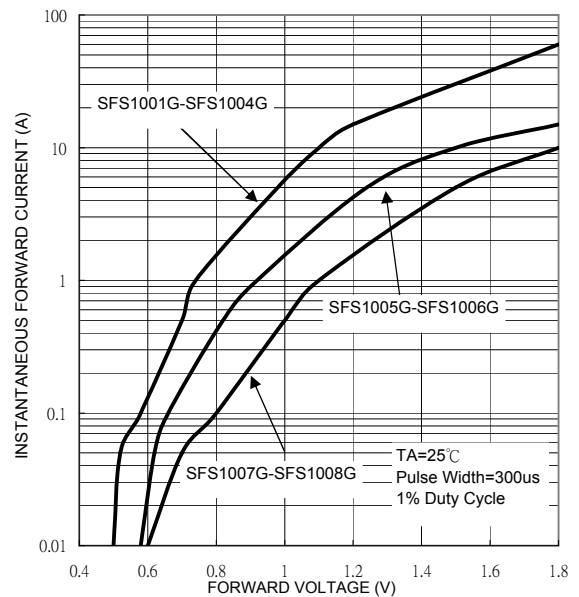

FIG. 4 TYPICAL JUNCTION CAPACITANCE

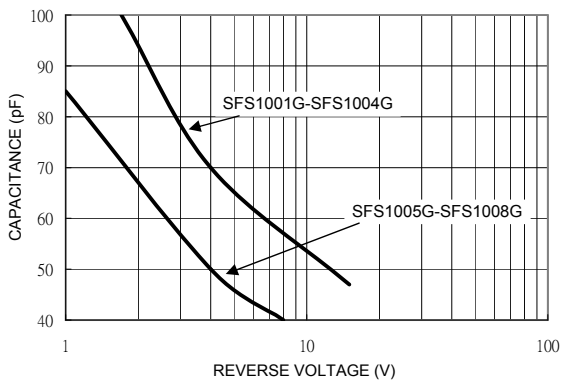

FIG.6- REVERSE RECOVERY TIME CHARACTERISTIC AND TEST CIRCUIT DIAGRAM

