

Features

- ✧ For surface mounted application in order to optimize board space
- ✧ Low profile package
- ✧ Built-in strain relief
- ✧ Glass passivated junction
- ✧ Excellent clamping capability
- ✧ Fast response time: Typically less than 1.0ps from 0 volt to BV min
- ✧ Typical I_R less than 1uA above 10V
- ✧ High temperature soldering guaranteed: 260°C / 10 seconds at terminals
- ✧ Meet MSL level 1, per J-STD-020D, lead free maximum peak of 260°C
- ✧ Plastic material used carries Underwriters Laboratory Flammability Classification 94V-0
- ✧ 1500 watts peak pulse power capability with a 10 / 1000 us waveform
- ✧ Green compound with suffix "G" on packing code & prefix "G" on datecode



Mechanical Data

- ✧ Case: Molded plastic
- ✧ Terminals: Solder plated
- ✧ Polarity: Indicated by cathode band
- ✧ Standard packaging: 16mm tape (EIA STD RS-481)
- ✧ Weight: 0.21 gram

Ordering Information (example)

Part No.	Package	Packing	Packing code	Green Compound Packing code
1.5SMC6.8	SMC	850 / 7" REEL	R7	R7G

Maximum Ratings and Electrical Characteristics

Rating at 25°C ambient temperature unless otherwise specified

Type Number	Symbol	Value	Unit
Peak Power Dissipation at $T_A=25^\circ\text{C}$, $T_p=1\text{ms}$ (Note 1)	P_{PK}	1500	Watts
Power Dissipation on Infinite Heatsink, $T_A=50^\circ\text{C}$	P_D	6.5	Watts
Peak Forward Surge Current, 8.3ms Single Half Sine-wave Superimposed on Rated Load (JEDEC method)(Note 2) - Unidirectional Only	I_{FSM}	200	Amps
Maximum Instantaneous Forward Voltage at 100A for Unidirectional Only (Note 3)	V_F	3.5 / 5.0	Volts
Thermal Resistance Junction to Ambient Air	$R_{\theta JA}$	50	°C/W
Thermal Resistance Junction to Leads	$R_{\theta JL}$	15	°C/W
Operating and Storage Temperature Range	T_J, T_{STG}	-55 to +150	°C

Note 1: Non-repetitive Current Pulse, Per Fig. 3 and Derated above $T_A=25^\circ\text{C}$ Per Fig. 2

Note 2: Mounted on 8mm x 8mm copper pads to each terminal

Note 3: $V_F=3.5\text{V}$ on 1.5SMC6.8 thru 1.5SMC91 Devices and $V_F=5.0\text{V}$ on 1.5SMC100 thru 1.5SMC200 Devices

Devices for Bipolar Applications

1. For Bidirectional Use C or CA Suffix for Types 1.5SMC6.8 through Types 1.5SMC200A
2. Electrical Characteristics Apply in Both Directions

RATINGS AND CHARACTERISTIC CURVES (1.5SMC SERIES)

FIG. 1 PEAK PULSE POWER RATING CURVE

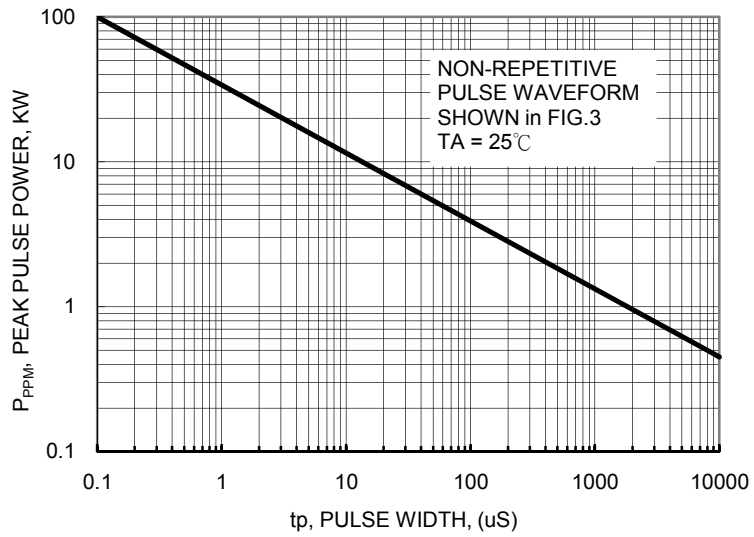

FIG.2 PULSE DERATING CURVE

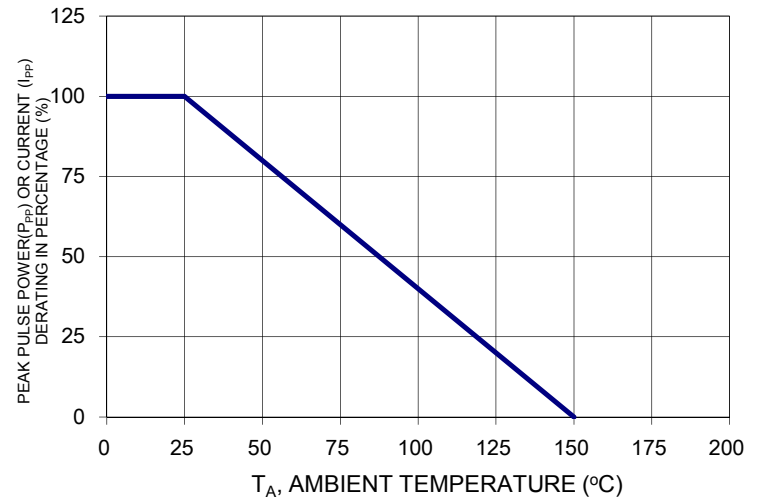

FIG. 3 CLAMPING POWER PULSE WAVEFORM

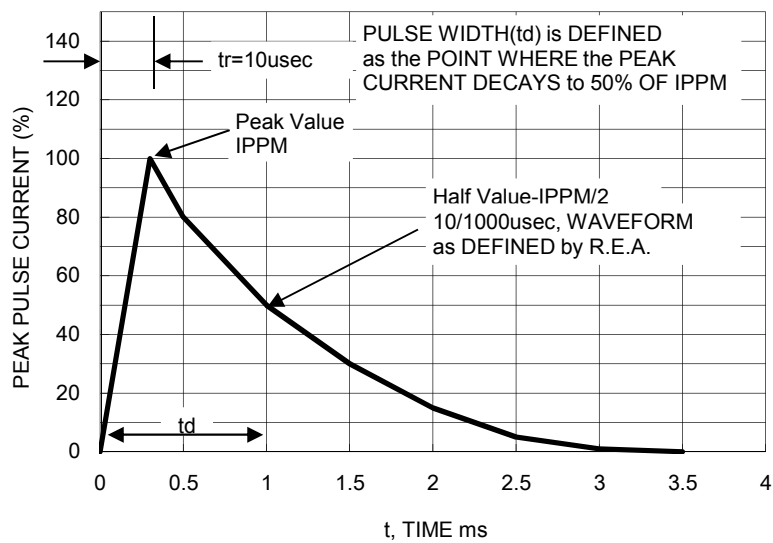

FIG. 4 MAXIMUM NON-REPETITIVE FORWARD SURGE CURRENT UNIDIRECTIONAL ONLY

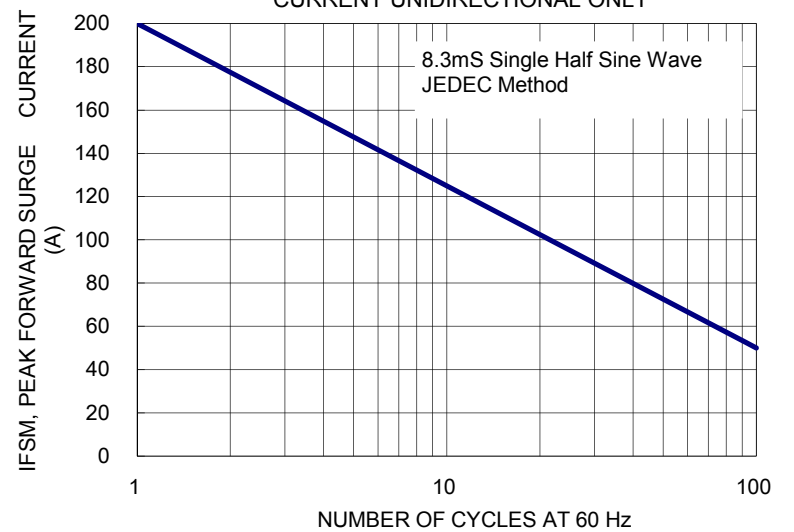
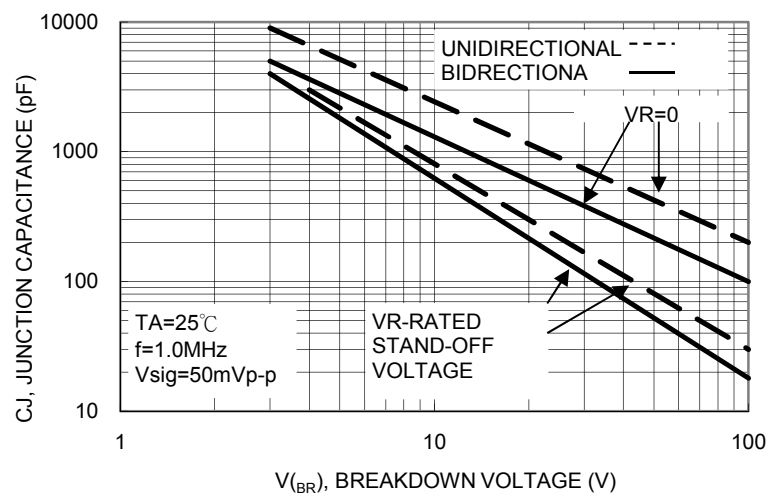

FIG. 5 TYPICAL JUNCTION CAPACITANCE



ELECTRICAL CHARACTERISTICS (TA=25°C unless otherwise noted)

GENERAL PART NUMBER	Device Marking Code	Breakdown Voltage VBR (V) (Note 1)		Test Current IT (mA)	Stand-Off Voltage V _{WM} (V)	Maximum Reverse Leakage @ V _{WM} ID (uA)	Maximum Peak Pulse Current IPPM (A) (Note 2)	Maximum Clamping Voltage @ IPPM V _c (V)	Maximum Temperature Coefficient of VBR(%/°C)
		Min	Max						
1.5SMC6.8	DDJ	6.12	7.48	10	5.50	1000	145	10.8	0.057
1.5SMC6.8A	DEJ	6.46	7.14	10	5.80	1000	150	10.5	0.057
1.5SMC7.5	DFJ	6.75	8.25	10	6.05	500	134	11.7	0.061
1.5SMC7.5A	DGJ	7.13	7.88	10	6.40	500	139	11.3	0.061
1.5SMC8.2	DHJ	7.38	9.02	10	6.63	200	126	12.5	0.065
1.5SMC8.2A	DKJ	7.79	8.61	10	7.02	200	130	12.1	0.065
1.5SMC9.1	DLJ	8.19	10.00	1.0	7.37	50	114	13.8	0.068
1.5SMC9.1A	DMJ	8.65	9.55	1.0	7.78	50	117	13.4	0.068
1.5SMC10	DNJ	9.00	11.00	1.0	8.10	10	105	15.0	0.073
1.5SMC10A	DPJ	9.50	10.5	1.0	8.55	10	108	14.5	0.073
1.5SMC11	DQJ	9.90	12.1	1.0	8.92	5.0	97	16.2	0.075
1.5SMC11A	DRJ	10.5	11.6	1.0	9.40	5.0	100	15.6	0.075
1.5SMC12	DSJ	10.8	13.2	1.0	9.72	5.0	91	17.3	0.078
1.5SMC12A	DTJ	11.4	12.6	1.0	10.2	5.0	94	16.7	0.078
1.5SMC13	DUJ	11.7	14.3	1.0	10.5	5.0	82	19.0	0.081
1.5SMC13A	DVJ	12.4	13.7	1.0	11.1	5.0	86	18.2	0.081
1.5SMC15	DWJ	13.5	16.5	1.0	12.1	5.0	71	22.0	0.084
1.5SMC15A	DXJ	14.3	15.8	1.0	12.8	5.0	74	21.2	0.084
1.5SMC16	DYJ	14.4	17.6	1.0	12.9	5.0	67	23.5	0.086
1.5SMC16A	DZJ	15.2	16.8	1.0	13.6	5.0	70	22.5	0.086
1.5SMC18	EDJ	16.2	19.8	1.0	14.5	5.0	59	26.5	0.088
1.5SMC18A	EEJ	17.1	18.9	1.0	15.3	5.0	60	25.5	0.088
1.5SMC20	EFJ	18.0	22.0	1.0	16.2	5.0	54	29.1	0.090
1.5SMC20A	EGJ	19.0	21.0	1.0	17.1	5.0	56	27.7	0.090
1.5SMC22	EHJ	19.8	24.2	1.0	17.8	5.0	49	31.9	0.092
1.5SMC22A	EKJ	20.9	23.1	1.0	18.8	5.0	51	30.6	0.092
1.5SMC24	ELJ	21.6	26.4	1.0	19.4	5.0	45	34.7	0.094
1.5SMC24A	EMJ	22.8	25.2	1.0	20.5	5.0	47	33.2	0.094
1.5SMC27	ENJ	24.3	29.7	1.0	21.8	5.0	40	39.1	0.096
1.5SMC27A	EPJ	25.7	28.4	1.0	23.1	5.0	42	37.5	0.096
1.5SMC30	EQJ	27.0	33.0	1.0	24.3	5.0	36	43.5	0.097
1.5SMC30A	ERJ	28.5	31.5	1.0	25.6	5.0	38	41.4	0.097
1.5SMC33	ESJ	29.7	36.3	1.0	26.8	5.0	33	47.7	0.098
1.5SMC33A	ETJ	31.4	34.7	1.0	28.2	5.0	34	45.7	0.098
1.5SMC36	EUJ	32.4	39.6	1.0	29.1	5.0	30	52.0	0.099
1.5SMC36A	EVJ	34.2	37.8	1.0	30.8	5.0	31	49.9	0.099
1.5SMC39	EWJ	35.1	42.9	1.0	31.6	5.0	27	56.4	0.100
1.5SMC39A	EXJ	37.1	41.0	1.0	33.3	5.0	29	53.9	0.100
1.5SMC43	EYJ	38.7	47.3	1.0	34.8	5.0	25	61.9	0.101
1.5SMC43A	EZJ	40.9	45.2	1.0	36.8	5.0	26	59.3	0.101
1.5SMC47	FDJ	42.3	51.7	1.0	38.1	5.0	23	67.8	0.101
1.5SMC47A	FEJ	44.7	49.4	1.0	40.2	5.0	24	64.8	0.101
1.5SMC51	FFJ	45.9	56.1	1.0	41.3	5.0	21	73.5	0.102
1.5SMC51A	FGJ	48.5	53.6	1.0	43.6	5.0	22	70.1	0.102
1.5SMC56	FHJ	50.4	61.6	1.0	45.4	5.0	19	80.5	0.103
1.5SMC56A	FKJ	53.2	58.8	1.0	47.8	5.0	20	77.0	0.103

ELECTRICAL CHARACTERISTICS (TA=25°C unless otherwise noted)

GENERAL PART NUMBER	Device Marking Code	Breakdown Voltage VBR (V) (Note 1)		Test Current IT (mA)	Stand-Off Voltage VWM (V)	Maximum Reverse Leakage @ VWM ID (uA)	Maximum Peak Pulse Current IPPM (A) (Note 2)	Maximum Clamping Voltage @ IPPM Vc(V)	Maximum Temperature Coefficient of VBR(%/°C)
		Min	Max						
1.5SMC62	FLJ	55.8	68.2	1.0	50.2	5.0	17	89.0	0.104
1.5SMC62A	FMJ	58.9	65.1	1.0	53.0	5.0	18	85.0	0.104
1.5SMC68	FNJ	61.2	74.8	1.0	55.1	5.0	16	98.0	0.104
1.5SMC68A	FPJ	64.6	71.4	1.0	58.1	5.0	17	92.0	0.104
1.5SMC75	FQJ	67.5	82.5	1.0	60.7	5.0	14	108	0.105
1.5SMC75A	FRJ	71.3	78.8	1.0	64.1	5.0	15	103	0.105
1.5SMC82	FSJ	73.8	90.2	1.0	66.4	5.0	13	118	0.105
1.5SMC82A	FTJ	77.9	86.1	1.0	70.1	5.0	13.9	113	0.105
1.5SMC91	FUJ	81.9	100	1.0	73.7	5.0	12	131	0.106
1.5SMC91A	FVJ	86.5	95.5	1.0	77.8	5.0	12.6	125	0.106
1.5SMC100	FWJ	90	110	1.0	81.0	5.0	10.9	144	0.106
1.5SMC100A	FXJ	95	105	1.0	85.5	5.0	11.4	137	0.106
1.5SMC110	FYJ	99	121	1.0	89.2	5.0	9.9	158	0.107
1.5SMC110A	FZJ	105	116	1.0	94.0	5.0	10.3	152	0.107
1.5SMC120	GDJ	108	132	1.0	97.2	5.0	9.1	173	0.107
1.5SMC120A	GEJ	114	126	1.0	102.0	5.0	9.5	165	0.107
1.5SMC130	GFJ	117	143	1.0	105.0	5.0	8.4	187	0.107
1.5SMC130A	GGJ	124	137	1.0	111.0	5.0	8.7	179	0.107
1.5SMC150	GHJ	135	165	1.0	121.0	5.0	7.3	215	0.108
1.5SMC150A	GKJ	143	158	1.0	128.0	5.0	7.6	207	0.108
1.5SMC160	GLJ	144	176	1.0	130.0	5.0	6.8	230	0.108
1.5SMC160A	GMJ	152	168	1.0	136.0	5.0	7.1	219	0.108
1.5SMC170	GNJ	153	187	1.0	138.0	5.0	6.4	244	0.108
1.5SMC170A	GPJ	162	179	1.0	145.0	5.0	6.7	234	0.108
1.5SMC180	GQJ	162	198	1.0	146.0	5.0	6.1	258	0.108
1.5SMC180A	GRJ	171	189	1.0	154.0	5.0	6.4	246	0.108
1.5SMC200	GSJ	180	220	1.0	162.0	5.0	5.4	287	0.108
1.5SMC200A	GTJ	190	210	1.0	171.0	5.0	5.7	274	0.108

Notes:

1. VBR measure after IT applied for 300us, IT=square wave pulse or equivalent.
2. Surge current waveform per Figure. 3 and derate per Figure. 2.
3. For bipolar types having VWM of 10 volts and under, the ID limit is doubled.
4. For bidirectional use C or CA suffix for types 1.5SMC6.8 through 1.5SMC200A
5. All terms and symbols are consistent with ANSI/IEEE C62.35.

Ordering information

Part No.	Package	Packing	Packing code	Green Compound Packing code
1.5SMCxxx (Note)	SMC	850 / 7" REEL	R7	R7G
	SMC	3K / 13" REEL	R6	R6G
	SMC	3K / 13" REEL	M6	M6G

Note: "x" is Device Code from "6.8" thru "200".

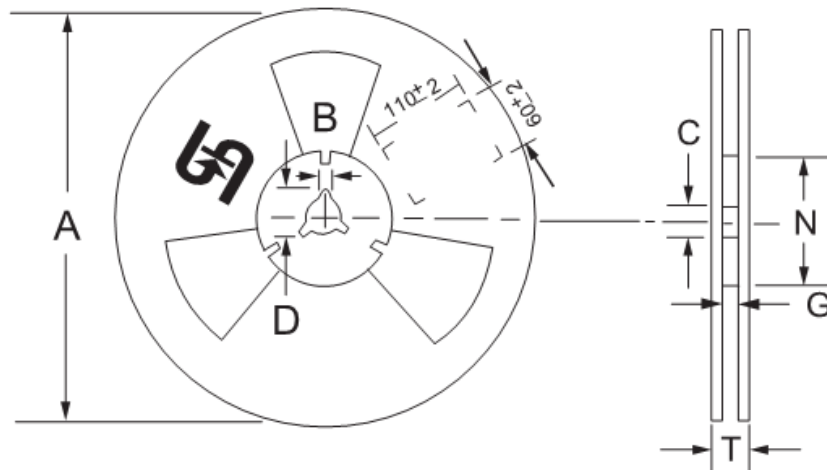
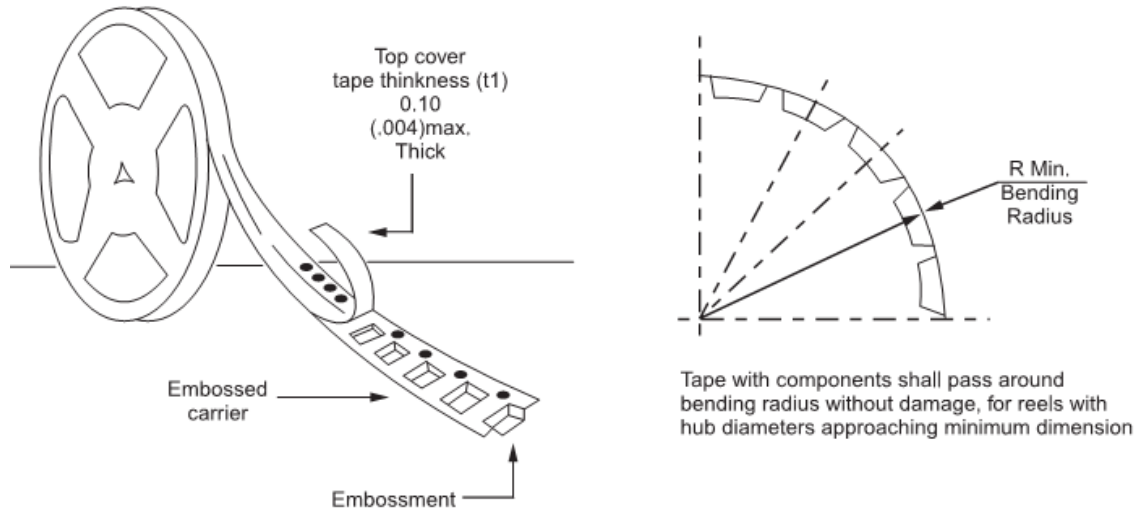
Tape & Reel specification

Reel Size	Tape Size	A	B	C	D	N	G	T
		±2.0	±0.4	+0.5;-0.2	min	±1.0	+0.8;-0	max
7"	16mm	178	1.9	13	21	62	16.2	18.6
Reel Size	Tape Size	A	B	C	D	N	G	T
		max	±0.5	±0.5	min	±0.5	+2.0;-0	max
13"	16mm	330	2	13	20.2	75	16.4	22.4

Unit (mm)

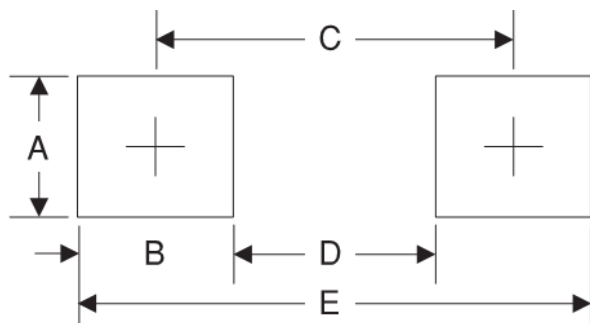
Suggested PAD Layout

Symbol	Unit(mm)
A	3.3
B	2.5
C	6.8
D	4.4
E	9.3

Dimensions

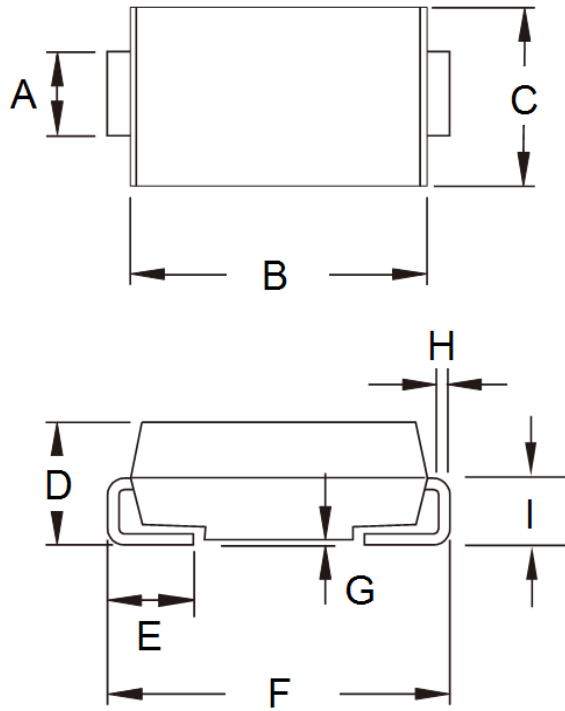

DIM.	Unit(mm)		Unit(inch)	
	Min	Max	Min	Max
A	2.90	3.20	0.114	0.126
B	6.60	7.11	0.260	0.280
C	5.59	6.22	0.220	0.245
D	2.00	2.62	0.079	0.103
E	1.00	1.60	0.039	0.063
F	7.75	8.13	0.305	0.320
G	0.10	0.20	0.004	0.008
H	0.15	0.31	0.006	0.012
I	1.26	1.56	0.050	0.061

Marking Diagram

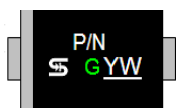

- P/N = Specific Device Code
- G = Green Compound
- YW = Date Code