



GBPC 15, 25, 35 SERIES

High Current 15, 25, 35 AMPS. Single Phase
Glass Passivated Bridge Rectifiers

GBPC, GBPC-W, GBPC-M

Dimensions in Page. 3

Features

- ✧ UL Recognized File # E-326243
- ✧ The plastic material used carries Underwriters Laboratory Flammability Classification 94V-0
- ✧ Integrally molded heatsink provide very low thermal resistance for maximum heat dissipation
- ✧ Surge overload ratings from 300 amperes to 400 amperes
- ✧ Typical IR less than 0.2 uA
- ✧ High temperature soldering guaranteed: 260°C/10 seconds at 5 lbs.,(2.3kg) tension
- ✧ Green compound with suffix "G" on packing code & prefix "G" on datecode

Mechanical Data

- ✧ Case: Molded plastic body
- ✧ Terminals: Pure tin plate, Lead free, leads solderable per MIL-STD-202, Method 208
- ✧ Weight: 16.95 grams
- ✧ Mounting Torque : 20 in-lbs Max.

Maximum Ratings and Electrical Characteristics

Rating at 25 °C ambient temperature unless otherwise specified.

Single phase, half wave, 60 Hz, resistive or inductive load.

For capacitive load, derate current by 20%

Type Number	Symbol	-005	-01	-02	-04	-06	-08	-10	Unit
Maximum Repetitive Peak Reverse Voltage	V_{RRM}	50	100	200	400	600	800	1000	V
Maximum RMS Voltage	V_{RMS}	35	70	140	280	420	560	700	V
Maximum DC Blocking Voltage	V_{DC}	50	100	200	400	600	800	1000	V
Maximum Average Forward Rectified Current @ $T_C=55^\circ C$ GBPC15 GBPC25 GBPC35	$I_{F(AV)}$				15 25 35				A
Peak Forward Surge Current,8.3 ms Single Half Sine-wave Superimposed on Rated Load (JEDEC method)	I_{FSM}				300 300 400				A
Maximum Instantaneous Forward Voltage Drop Per Element at Specified Current (Note 1)	V_F	GBPC15 7.5A GBPC25 12.5A GBPC35 17.5A			1.1				V
Maximum Reverse Current @ Rated VR	I_R				5				uA
Typical Thermal Resistance	$R_{\theta JC}$				1.5				°C/W
Operating Temperature Range	T_J				- 55 to + 150				°C
Storage Temperature Range	T_{STG}				- 55 to + 150				°C

Note 1 : Pulse Test with PW=300 usec, 1% Duty Cycle

Note 2 : Suffix "W" - Wire Lead Structure/"M" - Terminal Location Face to Face

(GBPC15005 THRU GBPC1510)
 RATINGS AND CHARACTERISTIC CURVES (GBPC25005 THRU GBPC2510)
 (GBPC35005 THRU GBPC3510)

FIG. 1 FORWARD CURRENT DERATING CURVE

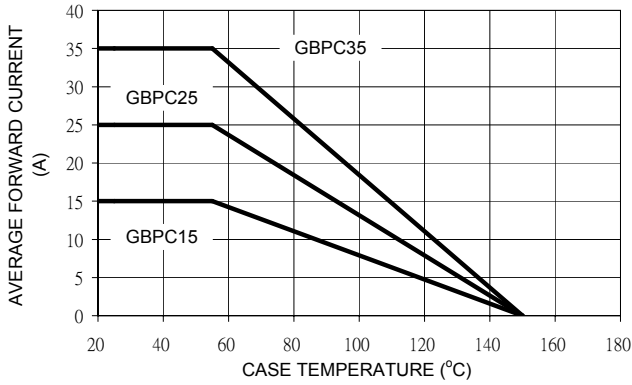

FIG. 2 TYPICAL REVERSE CHARACTERISTICS PER BRIDGE ELEMENT

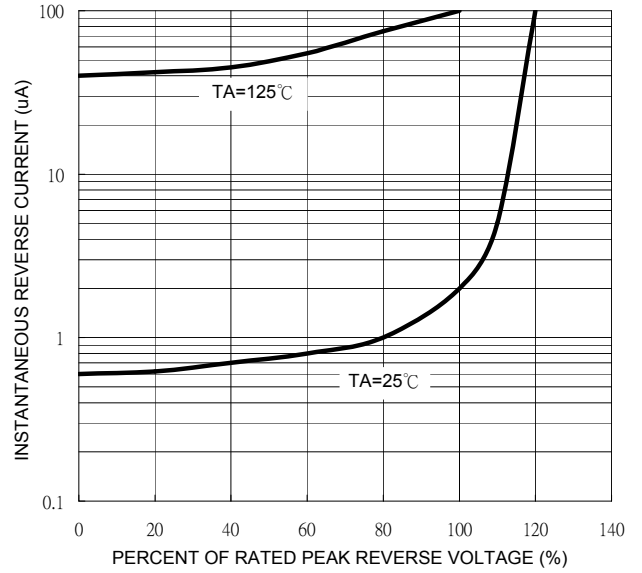

FIG. 3 MAXIMUM NON-REPETITIVE FORWARD SURGE CURRENT PER BRIDGE ELEMENT

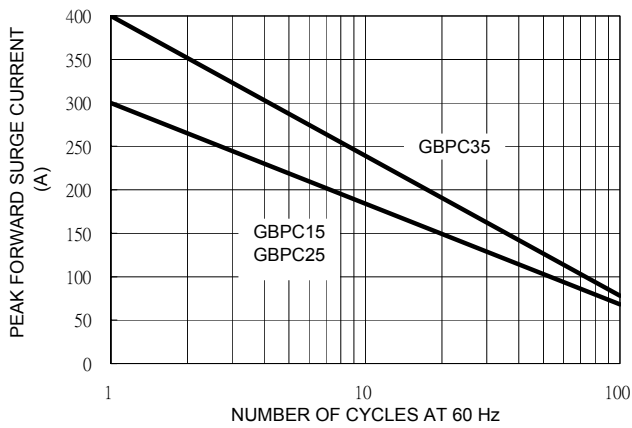

FIG. 5 TYPICAL FORWARD CHARACTERISTICS PER BRIDGE ELEMENT

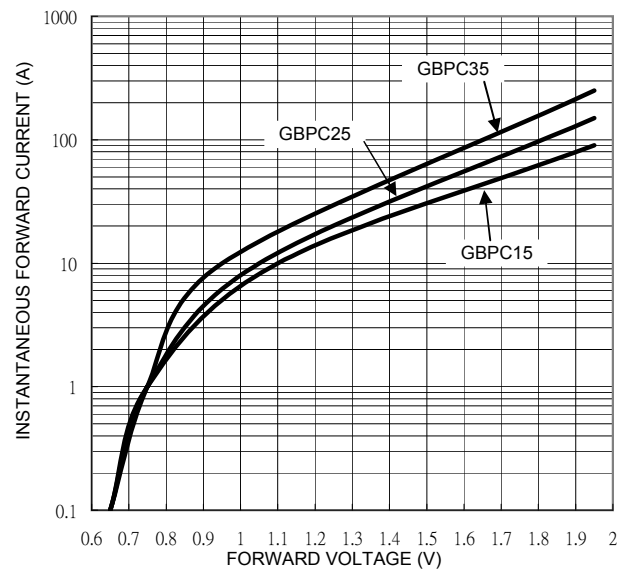
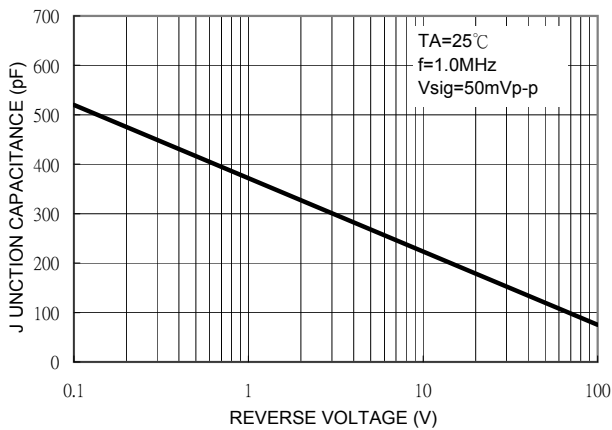

FIG. 4 TYPICAL JUNCTION CAPACITANCE



DIMENSIONS

(GBPC15005 THRU GBPC1510)
 (GBPC25005 THRU GBPC2510)
 (GBPC35005 THRU GBPC3510)

GBPC

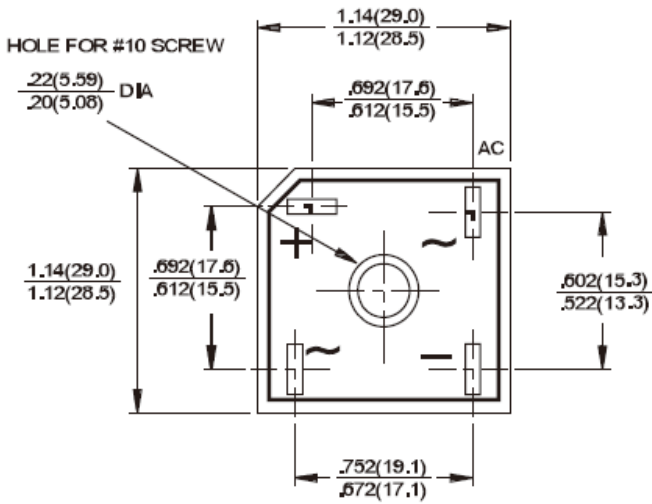

GBPC-W

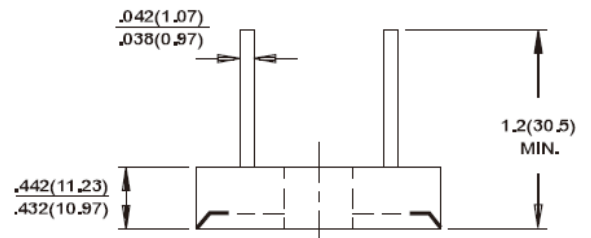
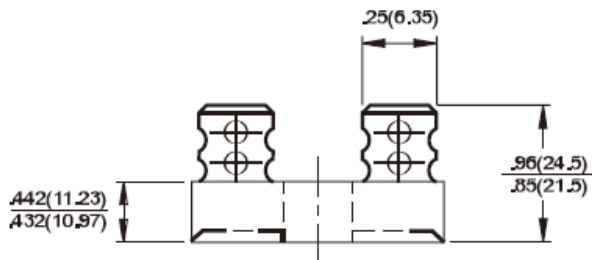
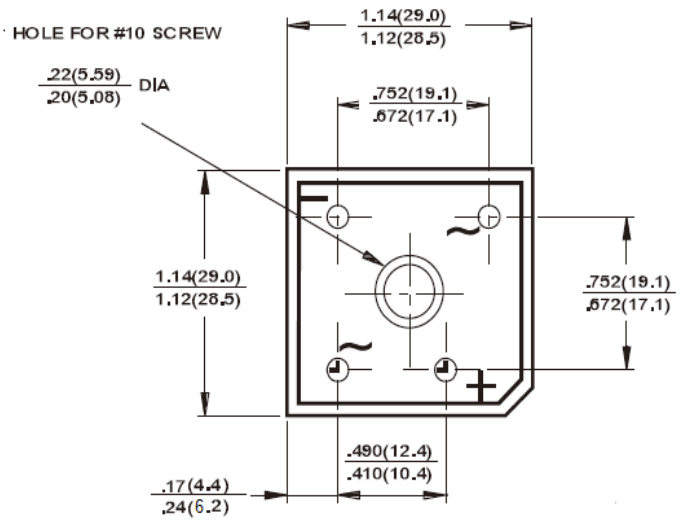

GBPC-M

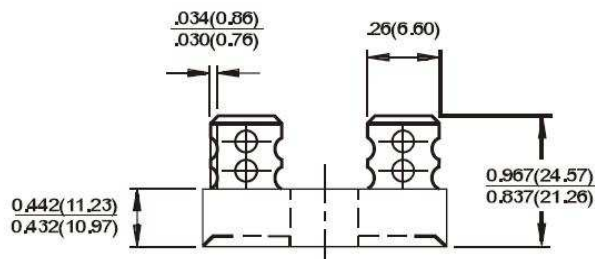
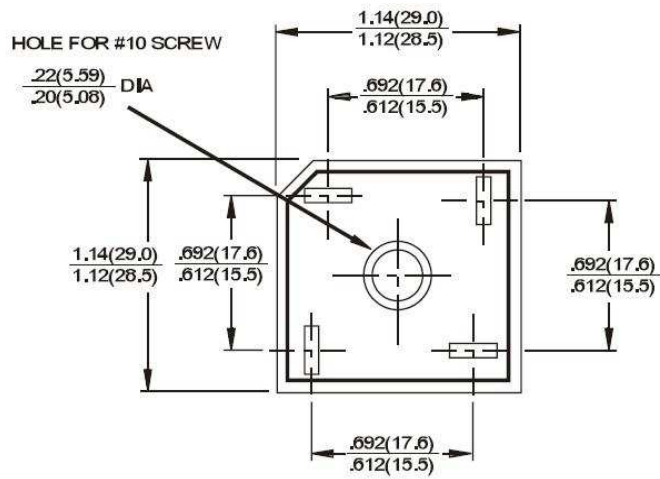

Dimensions in inches and (millimeters)