

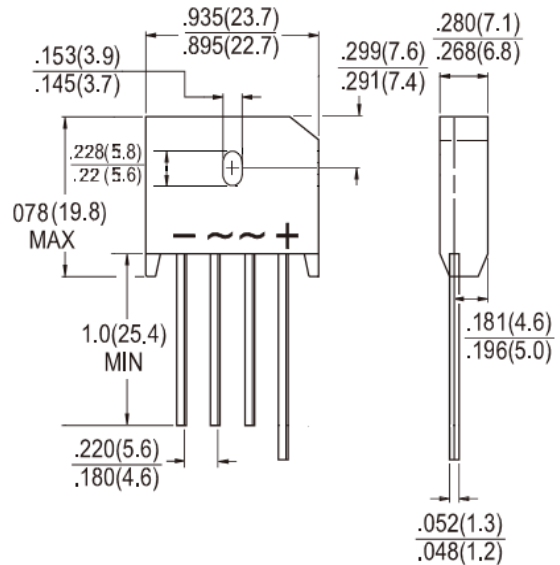

KBU1001G - KBU1007G

Single Phase 10.0AMPS. Glass Passivated Bridge Rectifiers

KBU



Features

- ✦ UL Recognized File # E-326243
- ✦ Ideal for printed circuit board
- ✦ High case dielectric strength
- ✦ Plastic material has Underwriters laboratory flammability Classification 94V-0
- ✦ Typical IR less than 0.1uA
- ✦ High surge current capability
- ✦ High temperature soldering guaranteed: 260 °C / 10 seconds at 5 lbs., (2.3kg) tension
- ✦ Green compound with suffix "G" on packing code & prefix "G" on datecode.

Mechanical Data

- ✦ Case: Molded plastic body
- ✦ Terminals: Pure tin plated, Lead free, Leads solderable per MIL-STD-202, Method 208
- ✦ Weight: 7.2 grams
- ✦ Mounting Torque: 5 in lbs max.

Dimensions in inches and (millimeters)

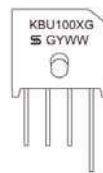

Marking Diagram

- KBU100XG = Specific Device Code
- G = Green Compound
- Y = Year
- WW = Work Week

Maximum Ratings and Electrical Characteristics

Rating at 25 °C ambient temperature unless otherwise specified.

Single phase, half wave, 60 Hz, resistive or inductive load.

For capacitive load, derate current by 20%

Type Number	Symbol	KBU 1001G	KBU 1002G	KBU 1003G	KBU 1004G	KBU 1005G	KBU 1006G	KBU 1007G	Units
Maximum Recurrent Peak Reverse Voltage	V_{RRM}	50	100	200	400	600	800	1000	V
Maximum RMS Voltage	V_{RMS}	35	70	140	280	420	560	700	V
Maximum DC Blocking Voltage	V_{DC}	50	100	200	400	600	800	1000	V
Maximum Average Forward Rectified Current @ $T_A=65^\circ C$	$I_{F(AV)}$	10							A
Peak Forward Surge Current, 8.3 ms Single Half Sine-wave Superimposed on Rated Load (JEDEC method)	I_{FSM}	200							A
Rating of fusing ($t < 8.3ms$)	I^2t	166							A ² S
Maximum Instantaneous Forward Voltage (Note 1) @ 5 A @ 10 A	V_F	1.0 1.1							V
Maximum DC Reverse Current @ $T_A=25^\circ C$ at Rated DC Blocking Voltage @ $T_A=125^\circ C$	I_R	5 500							uA
Typical Junction Capacitance per leg (Note 2)	C_j	400							pF
Typical Thermal Resistance	$R_{\theta JA}$ $R_{\theta JC}$	25 2.2							°C/W
Operating Temperature Range	T_J	- 55 to + 150							°C
Storage Temperature Range	T_{STG}	- 55 to + 150							°C

Note 1 : Pulse Test with PW=300 usec, 1% Duty Cycle.

Note 2 : Measured at 1MHz and applied Reverse bias of 4.0V D.C.

RATINGS AND CHARACTERISTIC CURVES (KBU1001G THRU KBU1007G)

FIG. 1 MAXIMUM DERATING CURVE FOR OUTPUT CURRENT

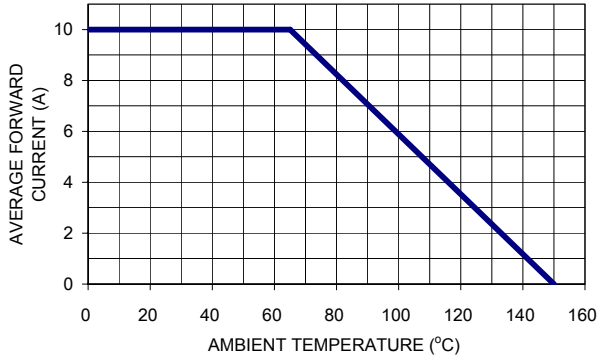

FIG. 2 MAXIMUM FORWARD SURGE CURRENT PER LEG

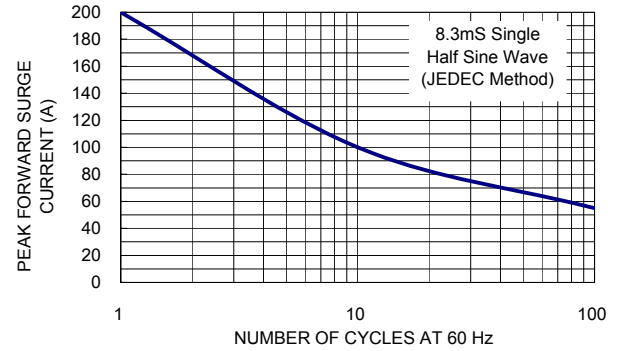

FIG. 3 TYPICAL REVERSE CHARACTERISTICS PER LEG

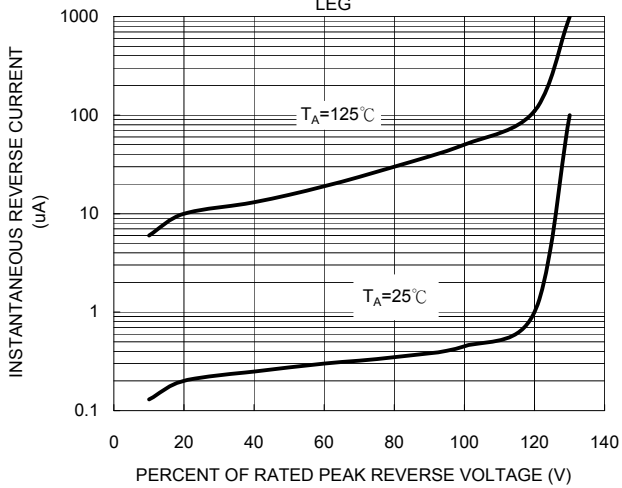

FIG. 4 TYPICAL FORWARD CHARACTERISTICS PER LEG

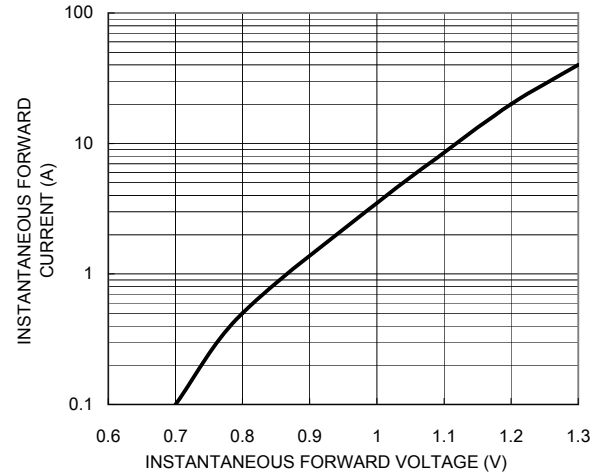

FIG. 5 TYPICAL JUNCTION CAPACITANCE

